



FUJI ELECTRIC

SPLIT TYPE ROOM AIR CONDITIONER

CEILING WALL type

SERVICE MANUAL

Models	Indoor unit	Outdoor unit
	RJW-18CC	ROW-18CC
	RJW-24CC	ROW-24CC
	RJW-30CC	ROW-30CC

C O N T E N T S

SPECIFICATIONS	1
OUTLINE AND DIMENSIONS	2
REFRIGERANT SYSTEM DIAGRAM	3
CIRCUIT DIAGRAM	5
INDOOR PRINTED CIRCUIT BOARD CIRCUIT DIAGRAM	7
P.C. BOARD LAYOUTS	9
ERROR CONTENTS	11
DISASSEMBLY ILLUSTRATION	12
PARTS LIST	27



Большая библиотека технической документации

<https://splitsystema48.ru/instrukcii-po-ekspluatácii-kondicionerov.html>

каталоги, инструкции, сервисные мануалы, схемы.

S P E C I F I C A T I O N S

TYPE	COOL		
INDOOR UNIT	RJW-18CC	RJW-24CC	RJW-30CC
OUTDOOR UNIT	ROW-18CC	ROW-24CC	ROW-30CC
COOLING CAPACITY (kW)	5.30 - 5.40	6.80 - 6.90	8.05 - 8.20

ELECTRICAL DATA

POWER SOURCE (V)	220 - 240		
FREQUENCY (Hz)	50		
RUNNING CURRENT (A)	9.8 - 9.4	12.0 - 12.3	14.9 - 15.5
INPUT WATTS (kW)	2.12 - 2.18	2.53 - 2.62	3.70 - 3.20
E.E.R. (kW/kW)	2.50 - 2.48	2.69 - 2.63	2.62 - 2.56
MOISTURE REMOVAL (ℓ/hr)	2.0	2.5	3.5
AIR CIRCULATION-Hi (m³/hr)	760	900	950

COMPRESSOR

TYPE	Hermetic type, Permanent split condenser, 2 poles, Single phase, Induction motor		
CODE	AWG5524EXC-4	H23B30QABKA	H23A42QABKA
REFRIGERANT R-22 (g)	1,300	1,950	2,350

FAN MOTOR

POWER SOURCE (V)	220 - 240		
INDOOR UNIT	TYPE	MFD-30HO	
	HI-SPEED (r.p.m.)	1,150	1,300
	MED-SPEED (r.p.m.)	1,030	1,160
	LO-SPEED (r.p.m.)	930	1,020
OUTDOOR UNIT	TYPE	MFB-247FBT	MFB-30DFT
	(r.p.m.)	735	730

DIMENSIONS

INDOOR UNIT	H x W x D	270 x 1,150 x 285	
OUTDOOR UNIT	(mm)	643 x 840 x 336	900 x 900 x 350

WEIGHT

INDOOR UNIT	GROSS / NET	20 / 16	
OUTDOOR UNIT	(kg)	74 / 66	75 / 67

REFRIGERANT CHARGE

PIPE LENGTH		7.5 m (25 ft)	10 m (33 ft)	15 m (49 ft)	20 m (66 ft)	25 m (82 ft)	30 m (98 ft)	Additional refrigerant
FULL CHARGE AMOUNT	RJW-18CC	1,300 g (45.9 oz)	1,350 g (47.6 oz)	1,450 g (51.1 oz)	1,550 g (54.7 oz)	—		20 g (0.71 oz)/1 m (3.3 ft) (over 7.5 m)
	RJW-24CC	1,950 g (68.8 oz)	2,000 g (70.5 oz)	2,100 g (74.1 oz)	2,200 g (77.6 oz)	—		
	RJW-30CC	2,350 g (82.9 oz)	2,400 g (84.7 oz)	2,500 g (88.2 oz)	2,600 g (91.7 oz)	2,700 g (95.2 oz)	2,800 g (98.8 oz)	

OUTLINE AND DIMENSIONS

Models : RJW-18CC
RJW-24CC
RJW-30CC

Unit : mm

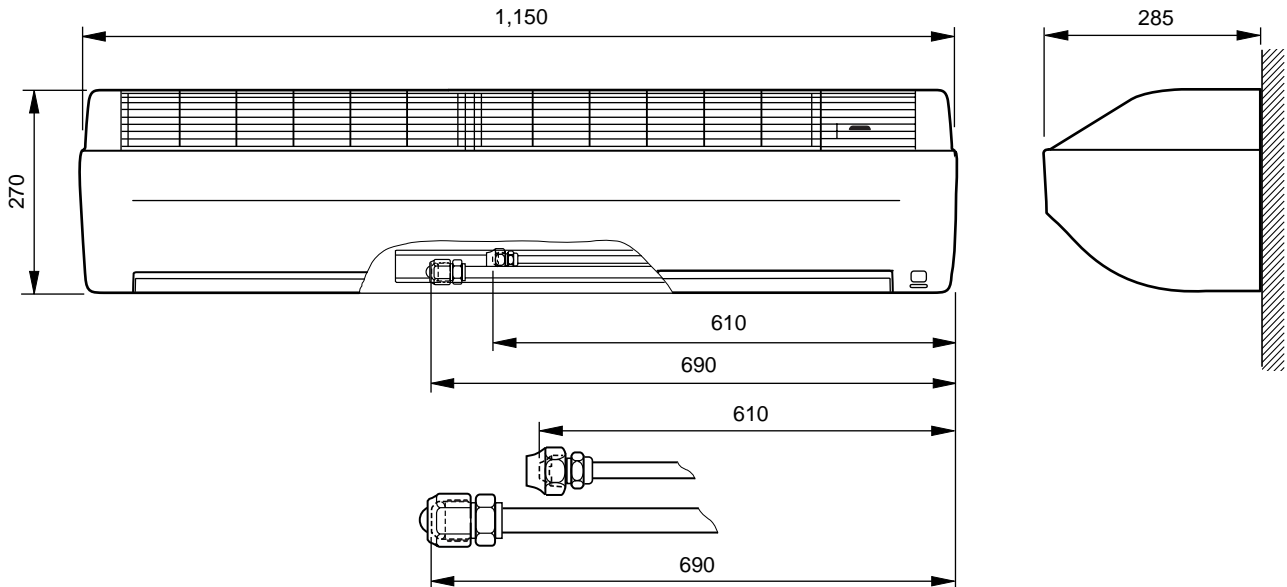

Models : ROW-18CC
ROW-24CC

Model : ROW-30CC

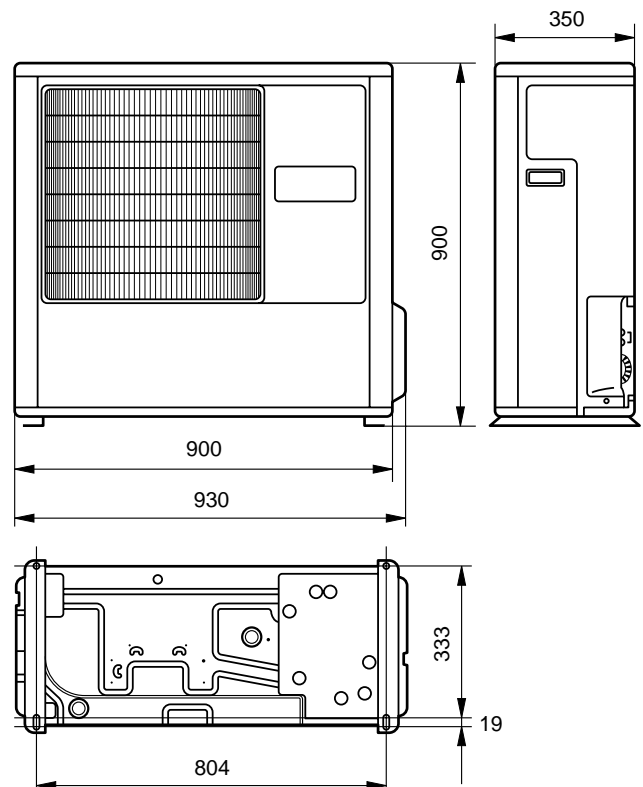
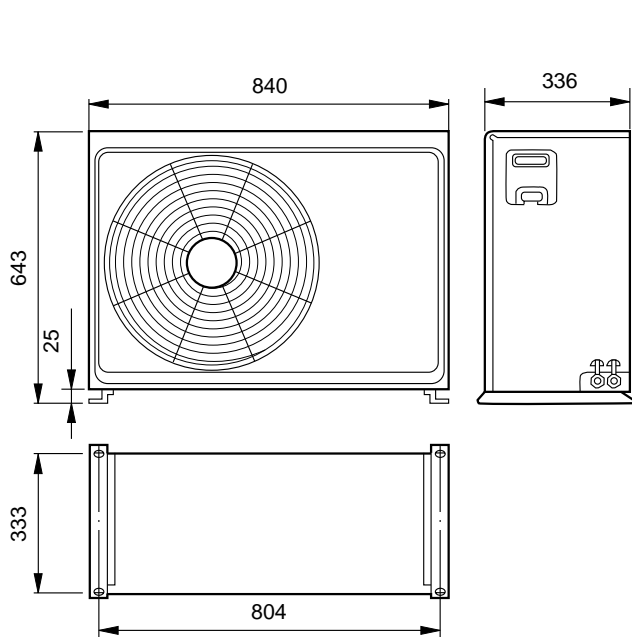

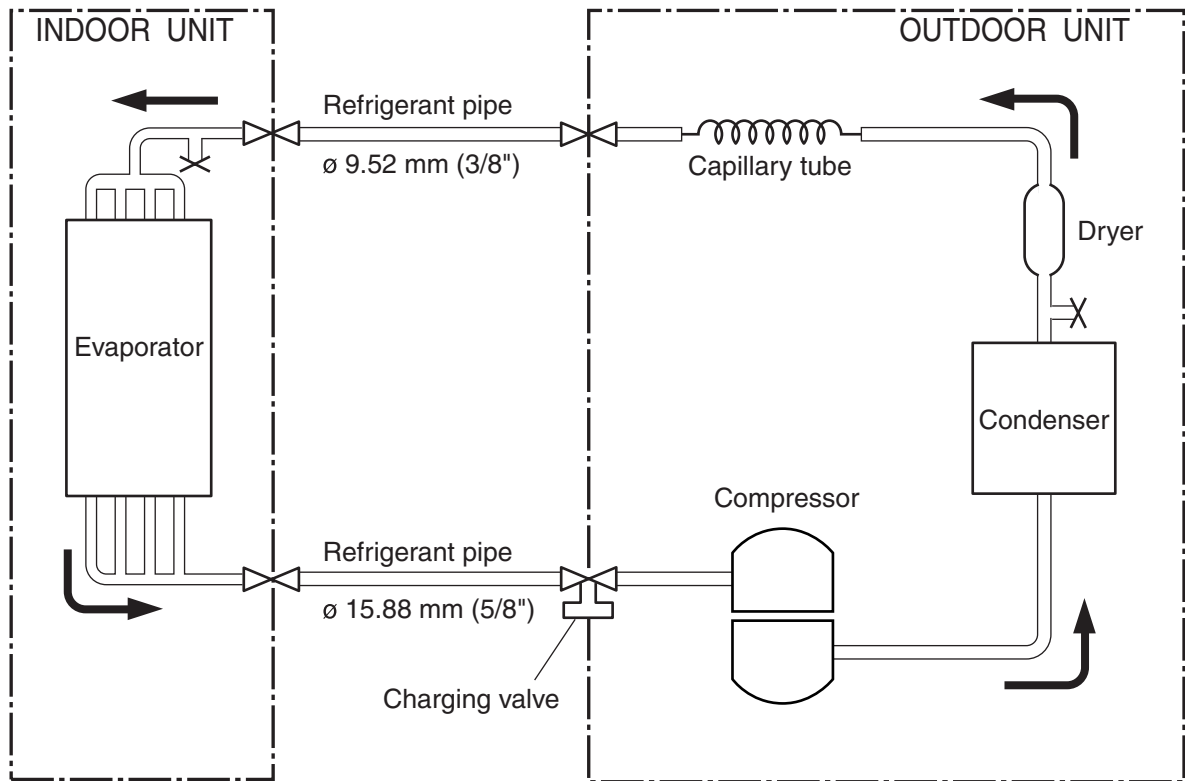

REFRIGERANT SYSTEM DIAGRAM

Models : RJW-18CC / ROW-18CC

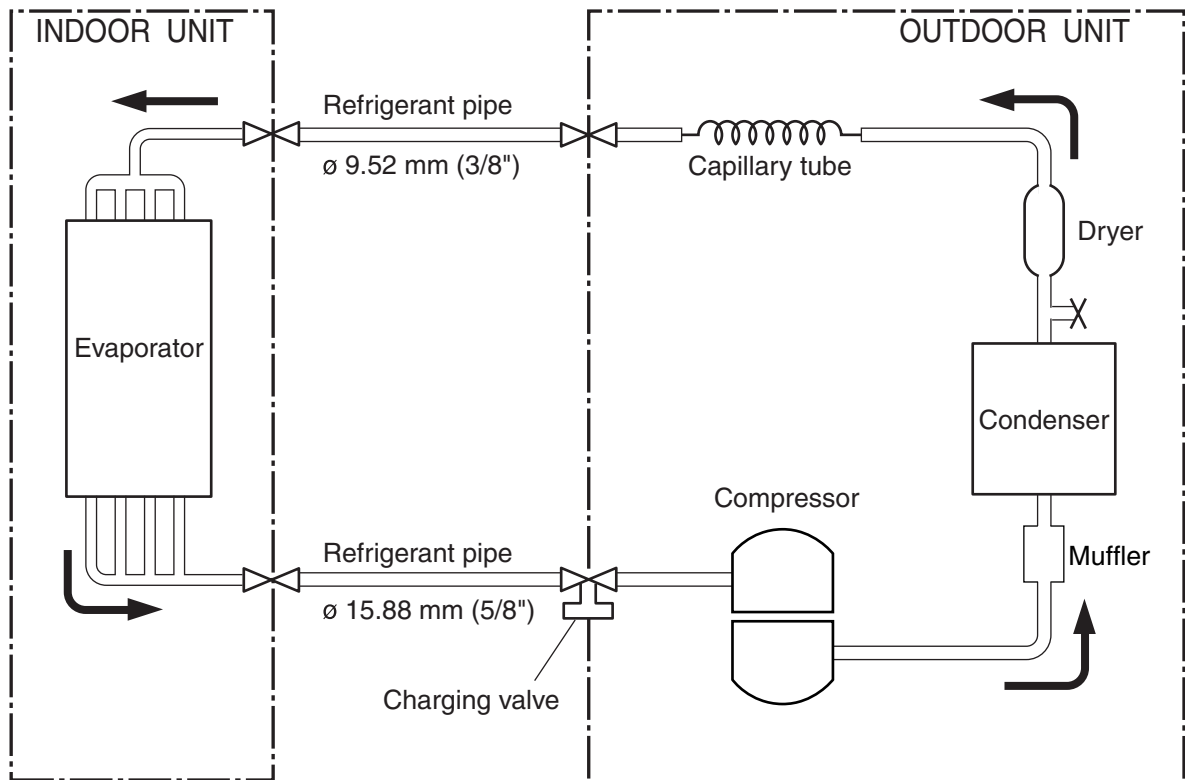

Models : RJW-24CC / ROW-24CC



 Cooling
 : Flare coupling

Models : RJW-30CC / ROW-30CC

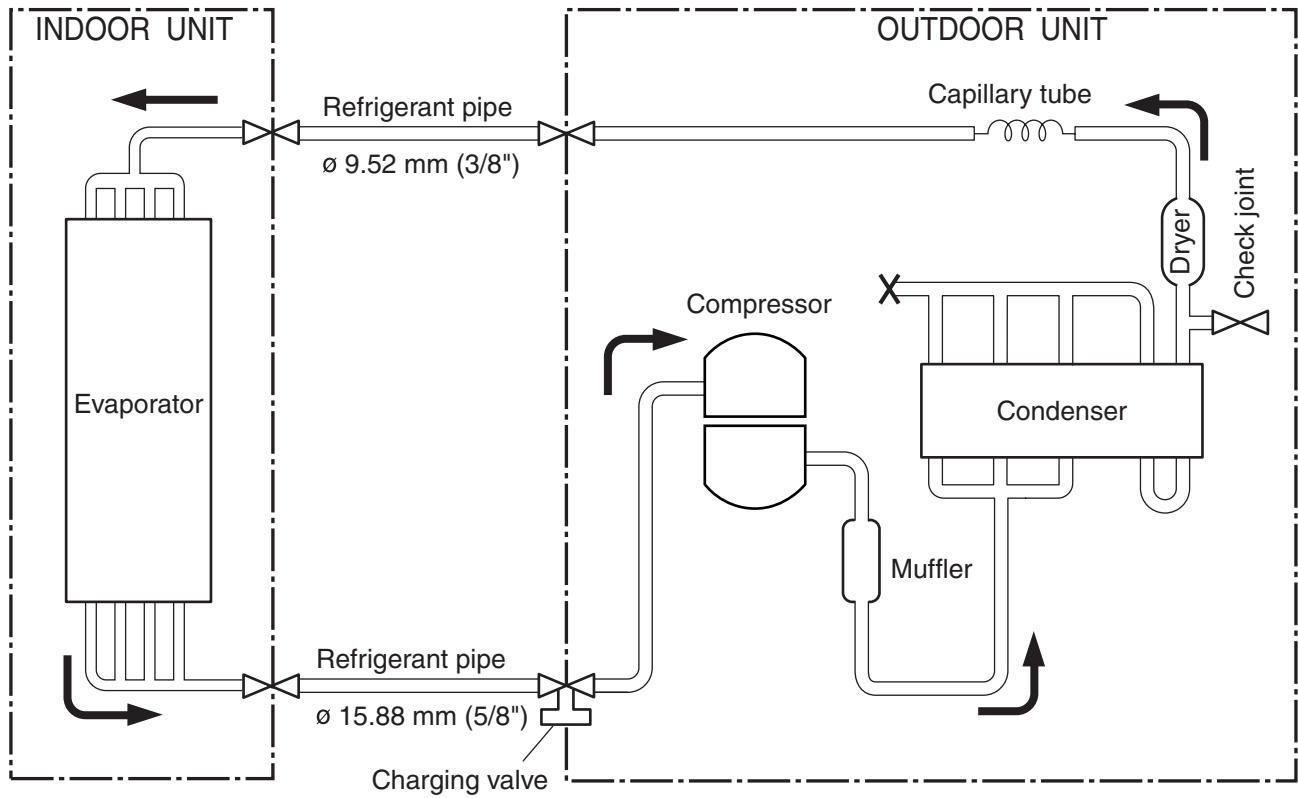

→ Cooling
⊗ : Flare coupling

CIRCUIT DIAGRAM

Models : RJW-18CC / ROW-18CC
 RJW-24CC / ROW-24CC

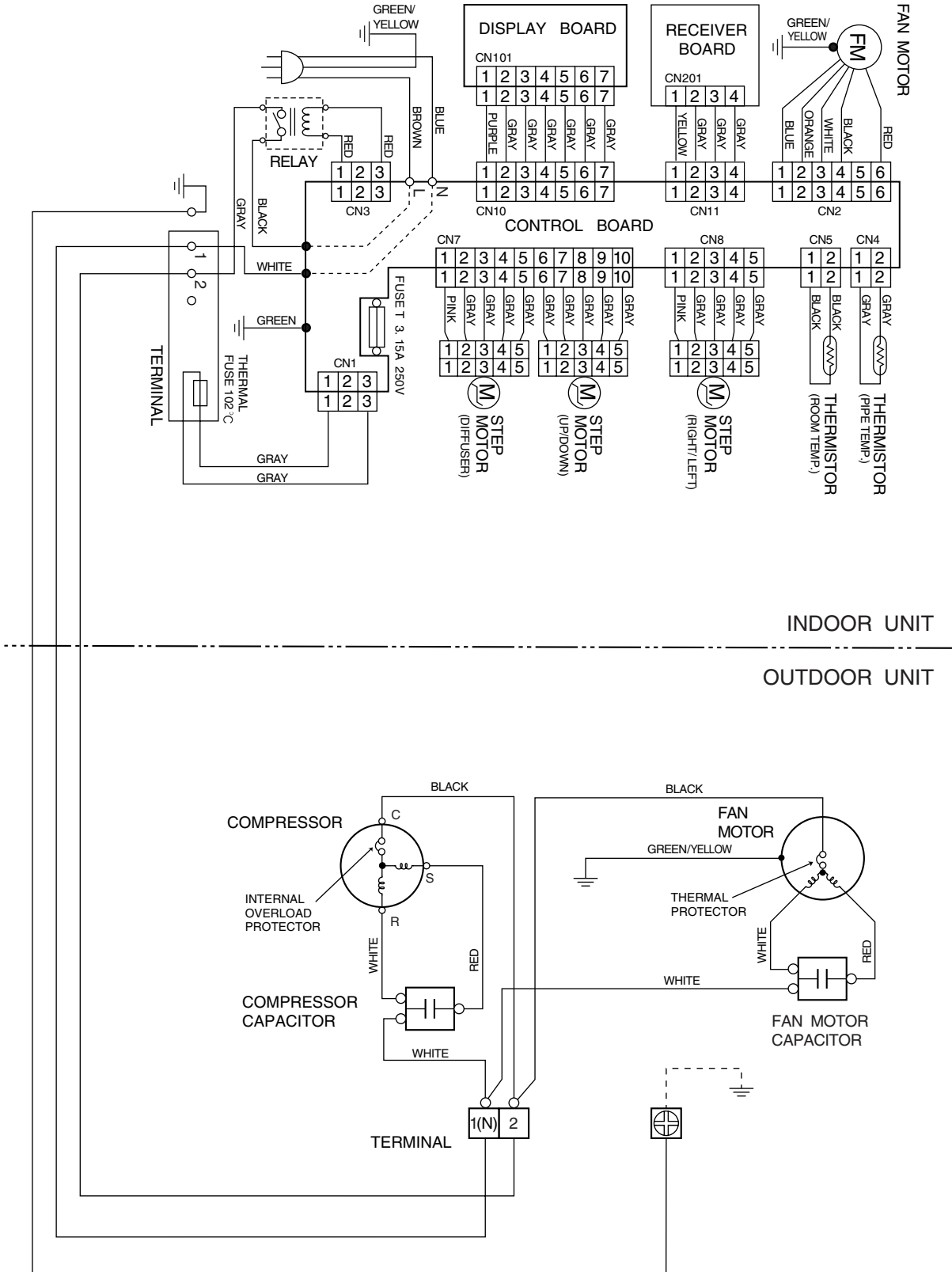

Models : RJW-30CC / ROW-30CC

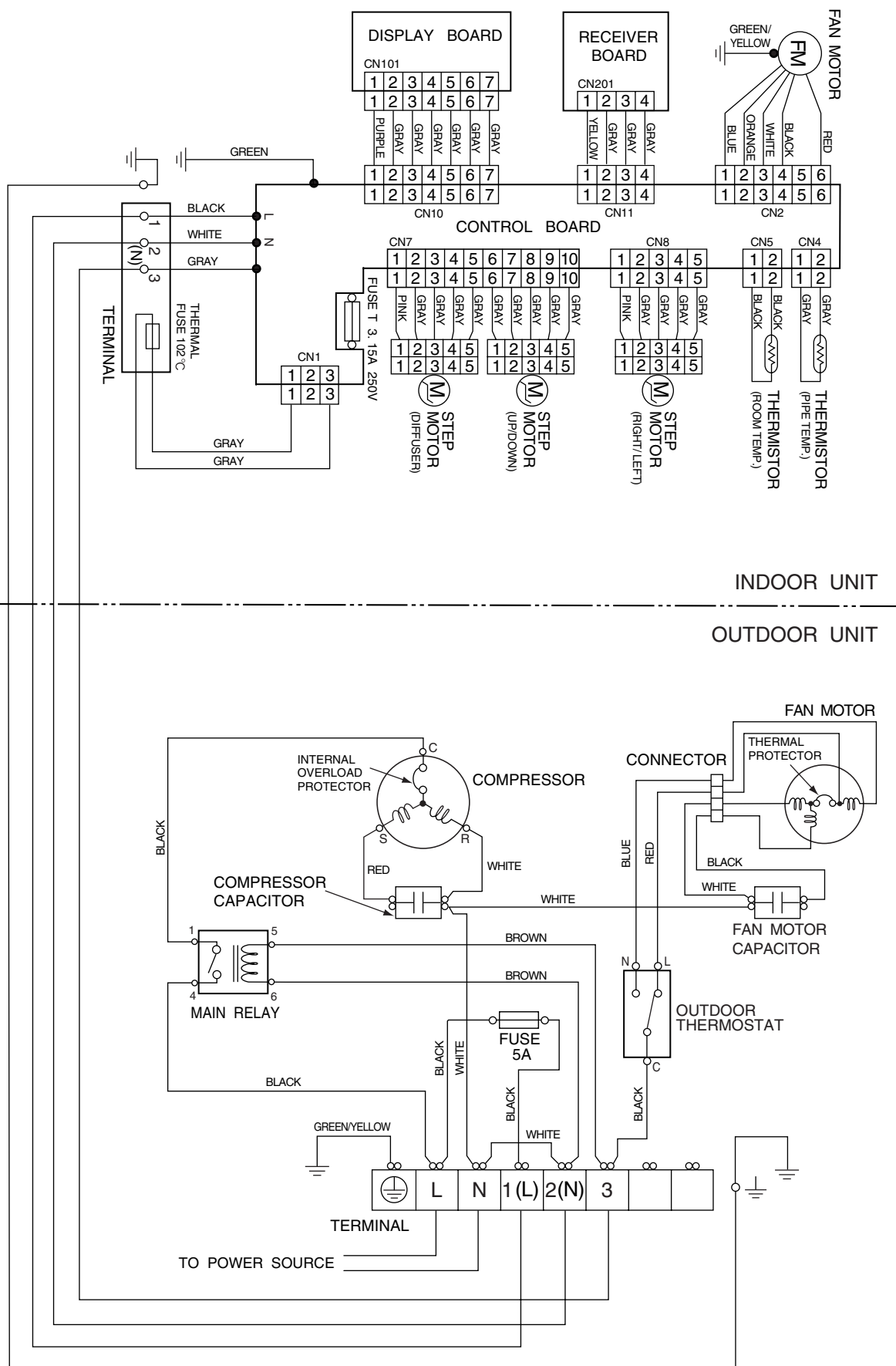

INDOOR PRINTED CIRCUIT BOARD CIRCUIT DIAGRAM

Models : RJW-18CC
RJW-24CC

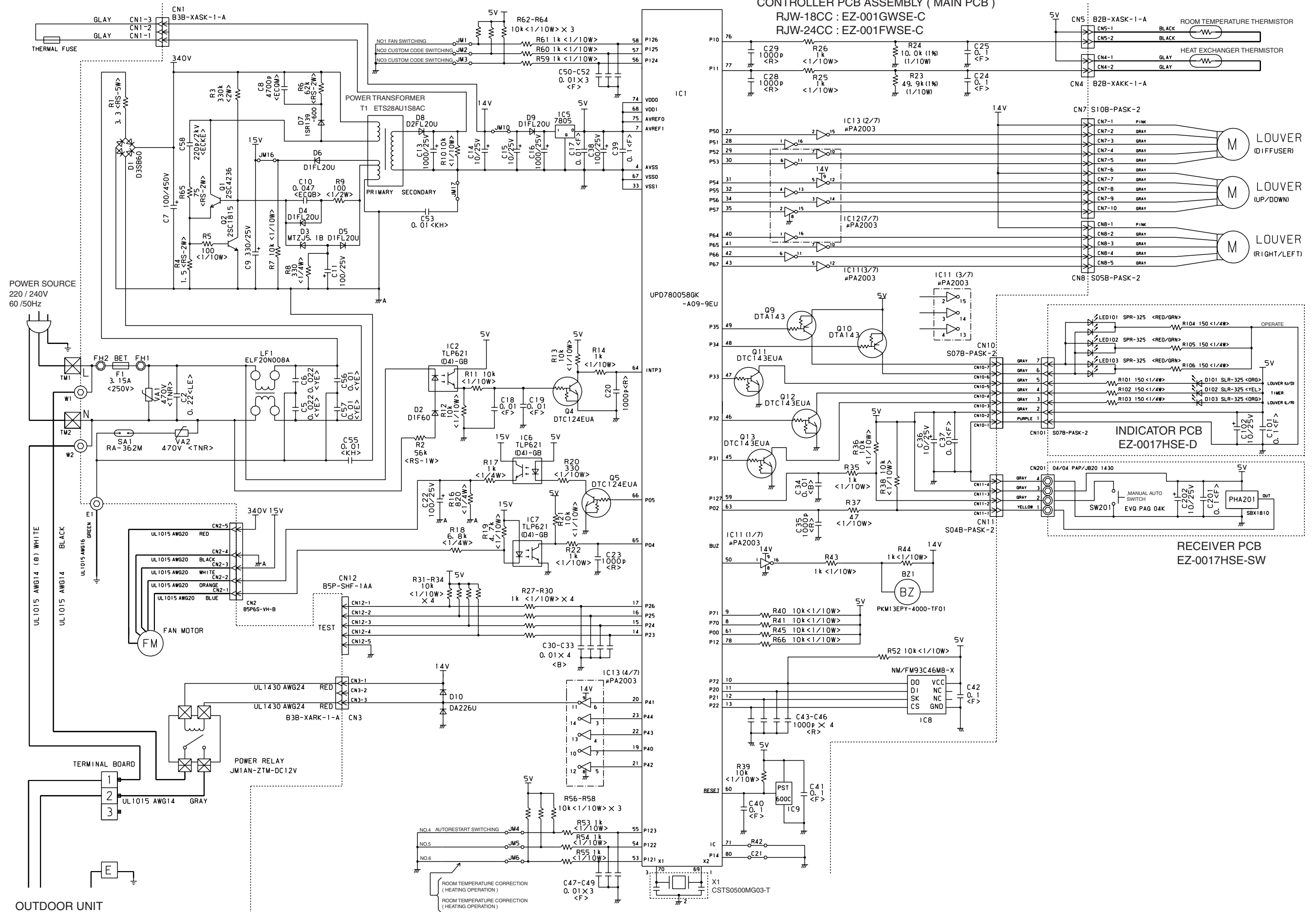

CONTROLLER PCB ASSEMBLY (MAIN PCB)
RJW-18CC : EZ-001GWSE-C
RJW-24CC : EZ-001FWSE-C

Model : RJW-30CC

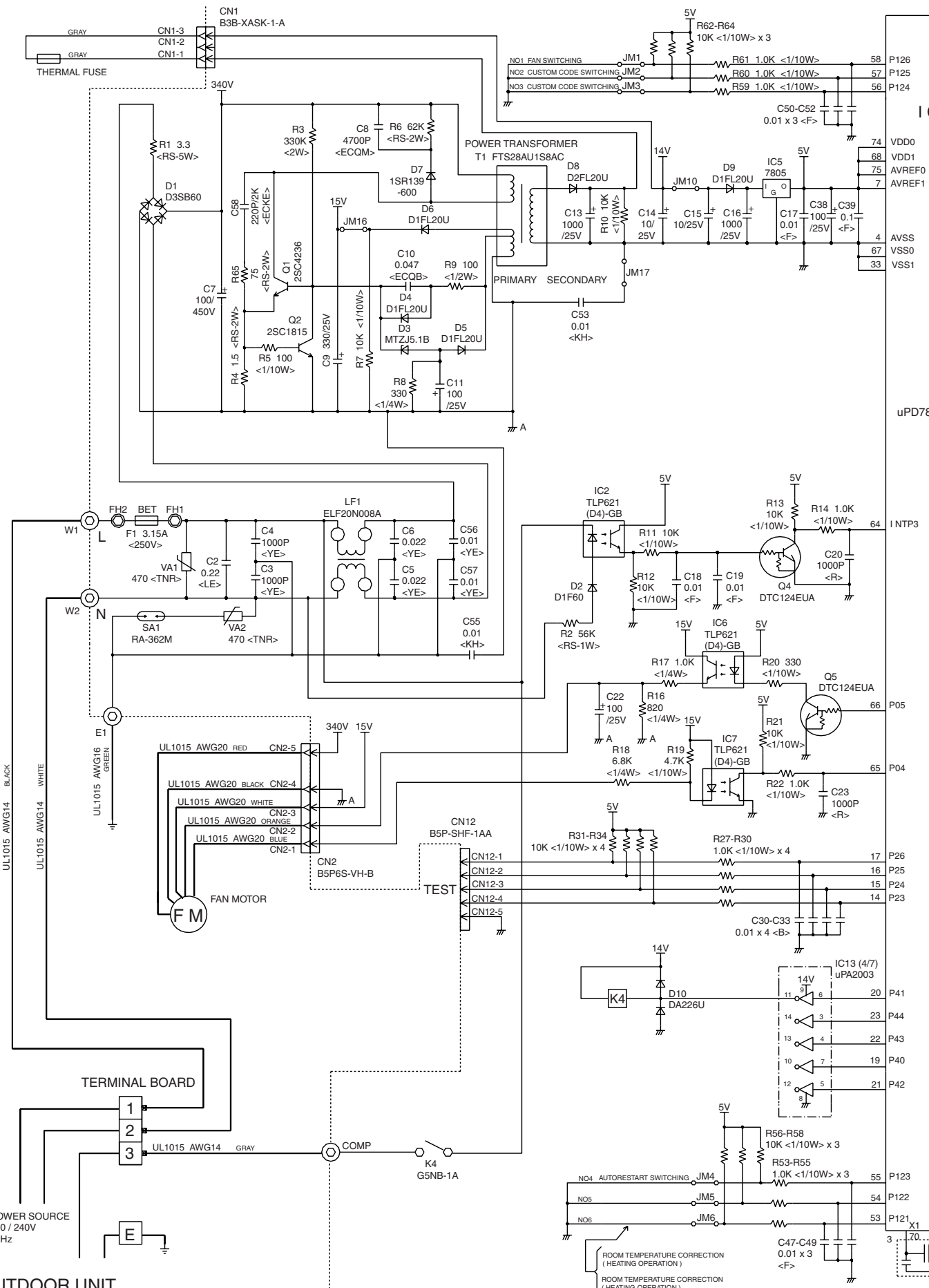

**CONTROLLER PCB ASSEMBLY (MAIN PCB)
RJW-30CC : EZ-001DWSE-C**

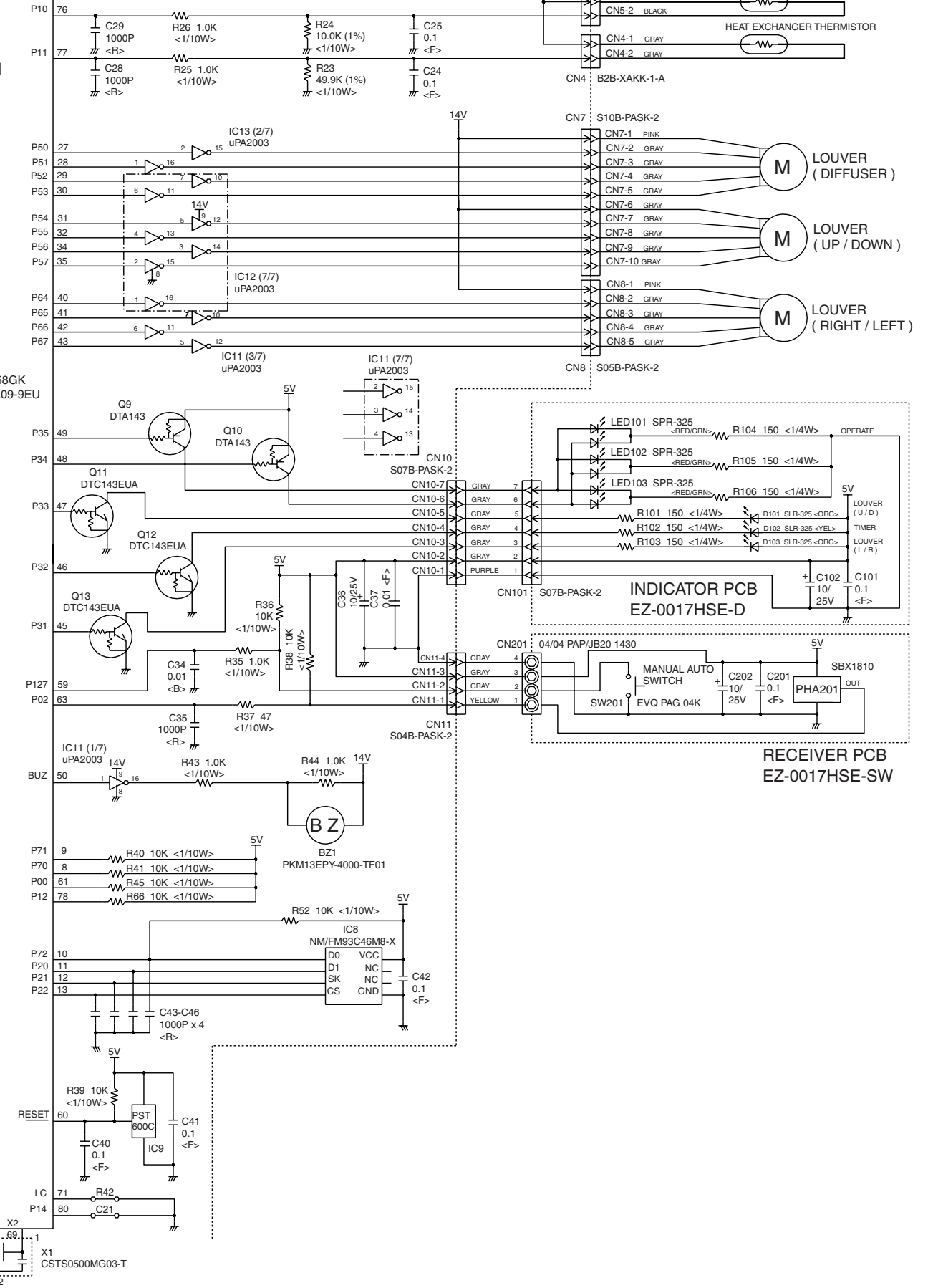

OUTDOOR UNIT

P.C.B.O.A.R.D LAYOUTS

CONTROLLER PCB ASSEMBLY (MAIN PCB)

(Viewed from the solder side)

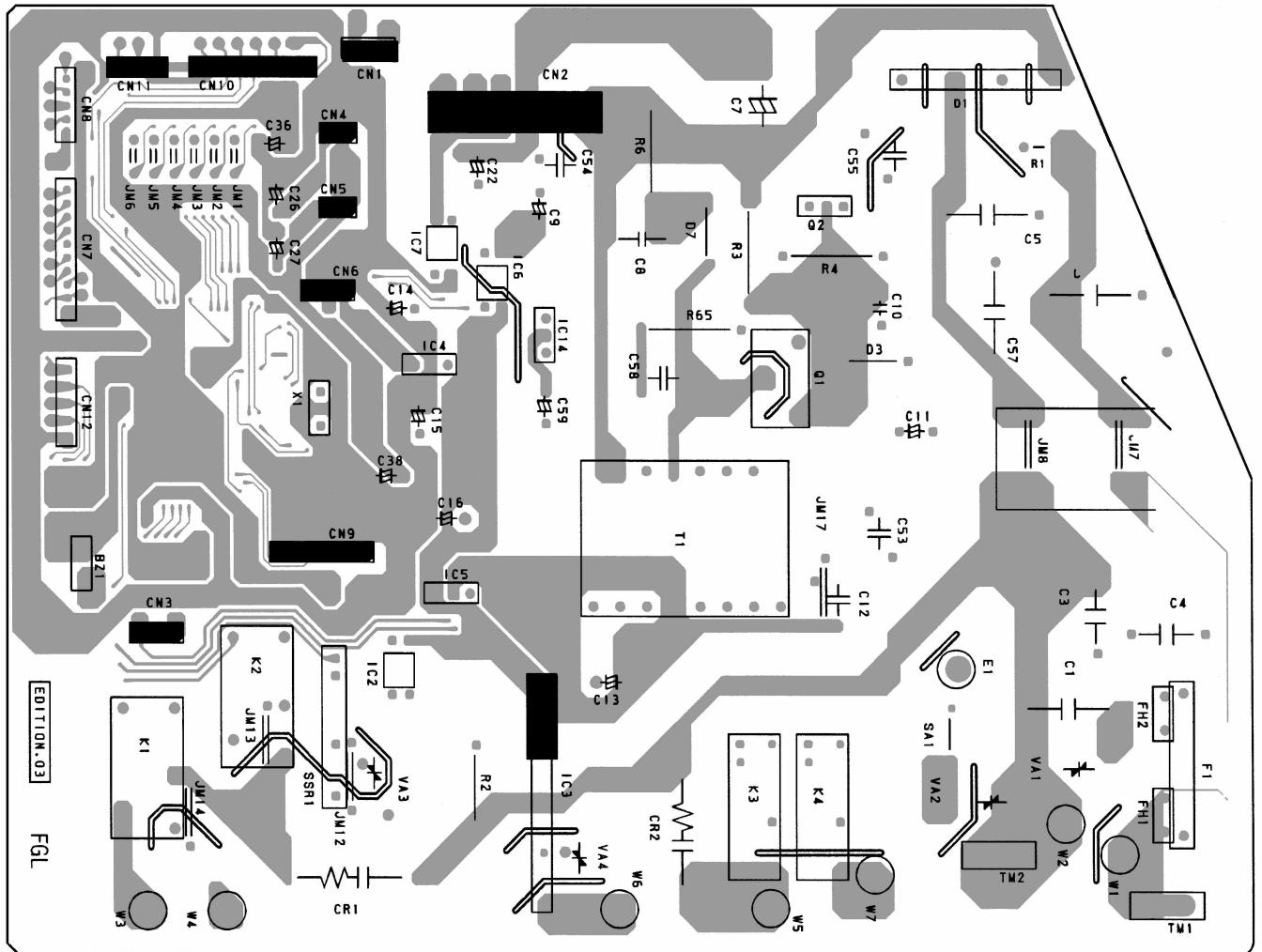

INDICATOR PCB ASSEMBLY

(Viewed from the solder side)

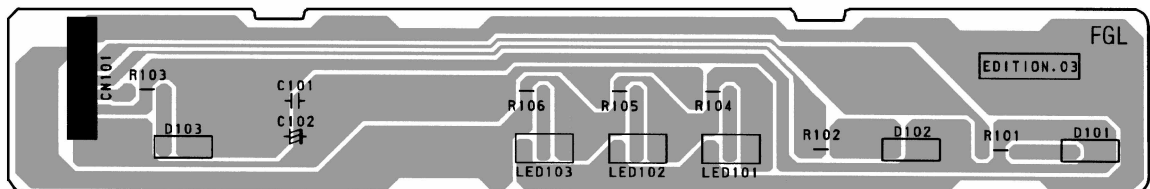

RECEIVER PCB ASSEMBLY

(Viewed from the solder side)

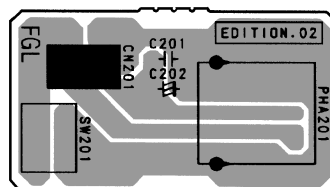

CONTROLLER PCB ASSEMBLY (MAIN PCB)

(Viewed from the component side)

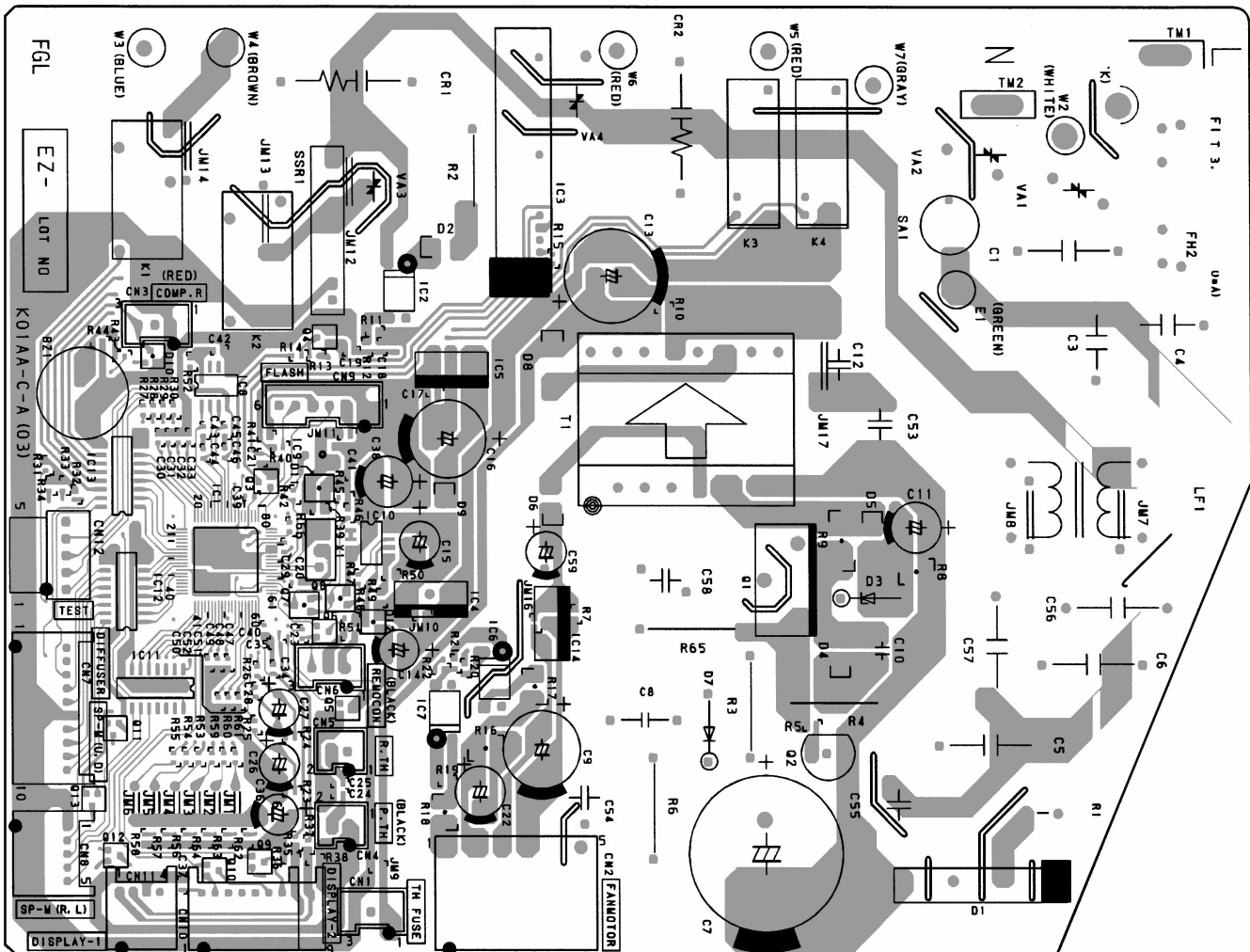

INDICATOR PCB ASSEMBLY

(Viewed from the component side)

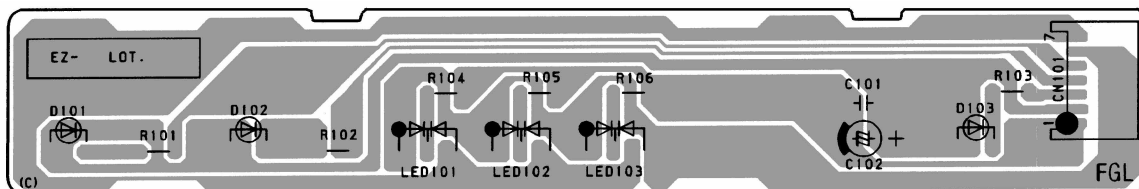

RECEIVER PCB ASSEMBLY

(Viewed from the component side)

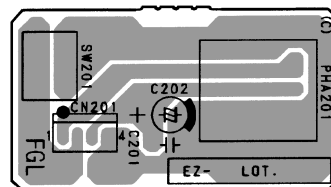

E R R O R C O N T E N T S

● Error

The OPERATION, TIMER and SWING lamps operate as follows according to the error contents.

○ : Fast flashing ● : Slow flashing – : Off

Error contents	Error display		
	OPERATION (RED)	TIMER (YELLOW)	SWING (ORANGE)
Indoor unit circuit board error	○	○	–
Indoor unit room temperature sensor wire opened	2 times ●	○	–
Indoor unit room temperature sensor wire short circuited	2 times ●	○	○
Indoor unit piping sensor wire opened	3 times ●	○	–
Indoor unit piping sensor wire short circuited	3 times ●	○	○
Indoor unit fan error	6 times ●	○	–

DISASSEMBLY ILLUSTRATION

Models : RJW-18CC
RJW-24CC
RJW-30CC

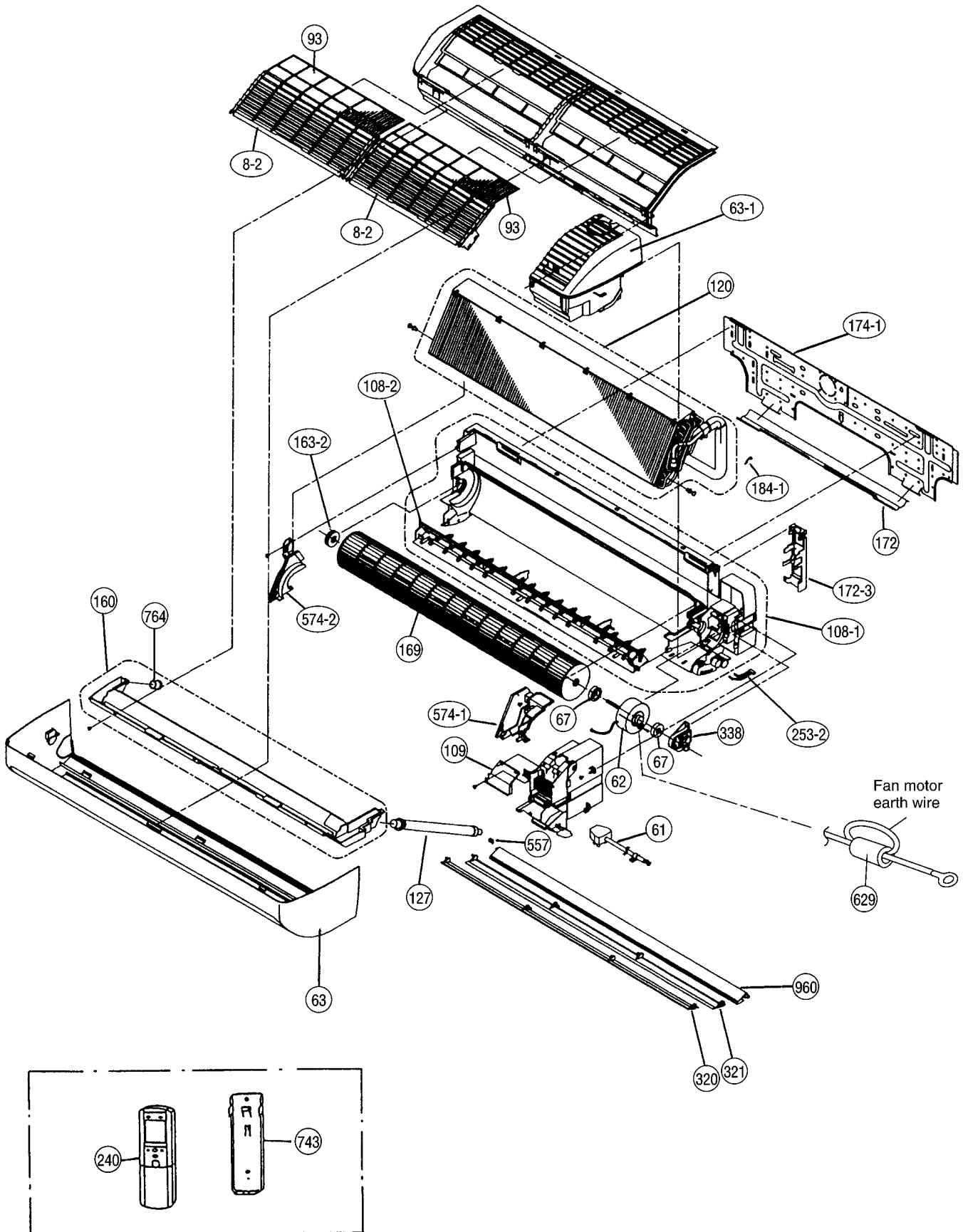

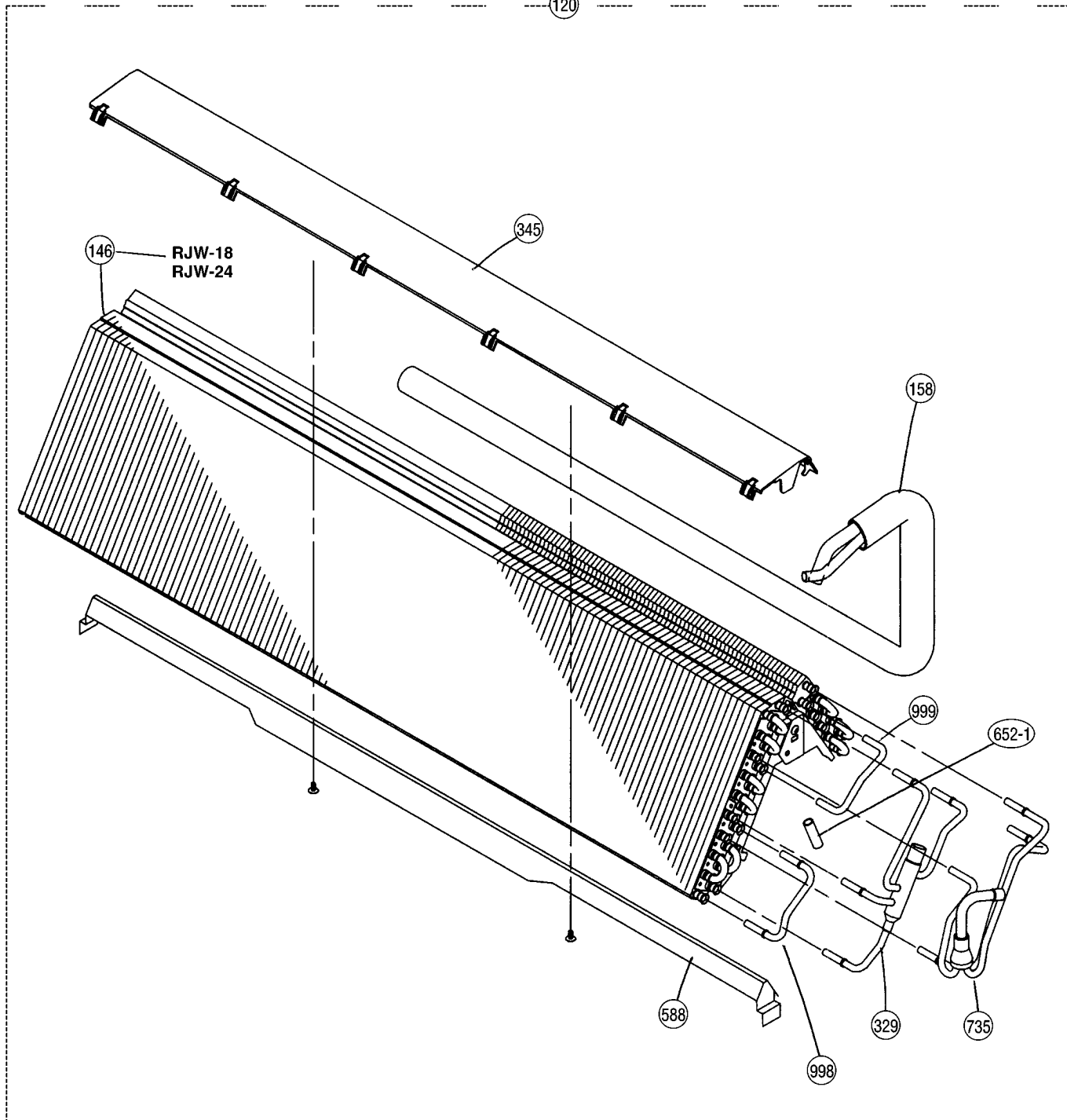

Model : RJW-18CC

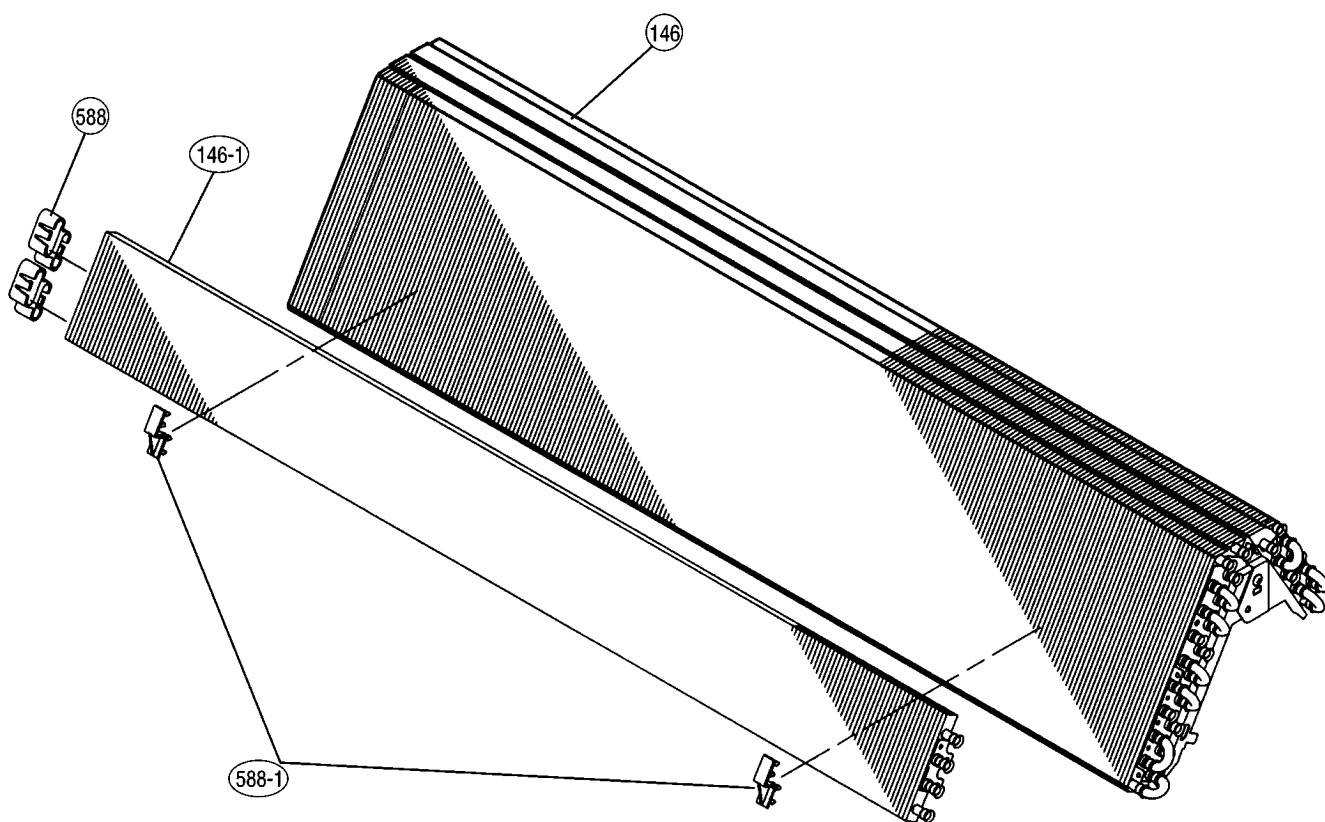

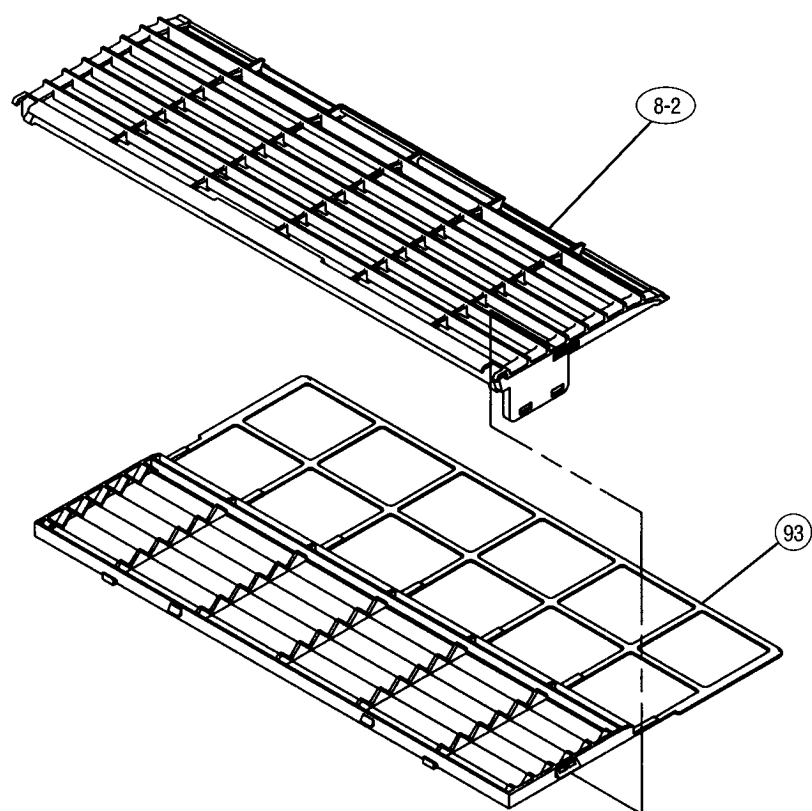

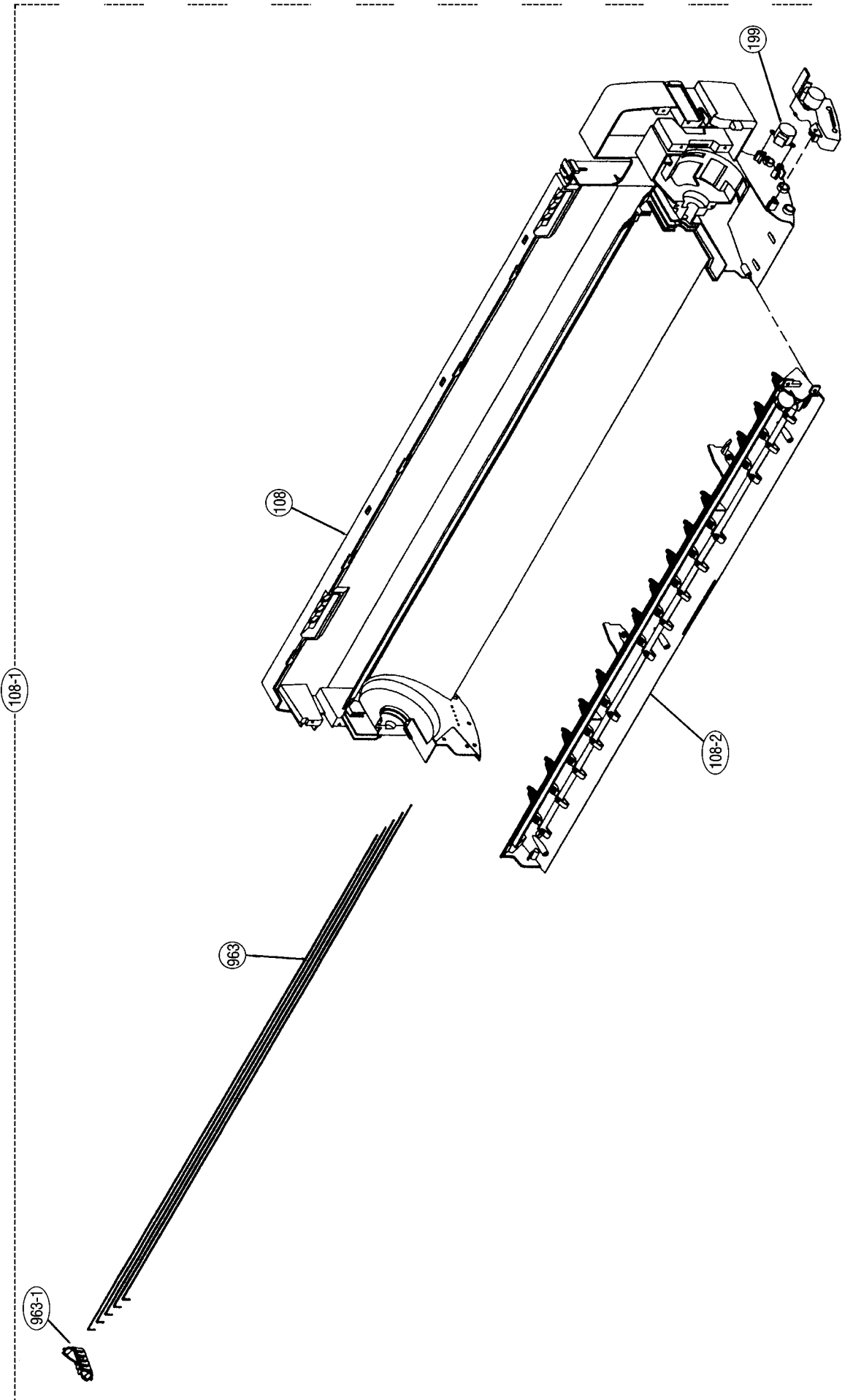

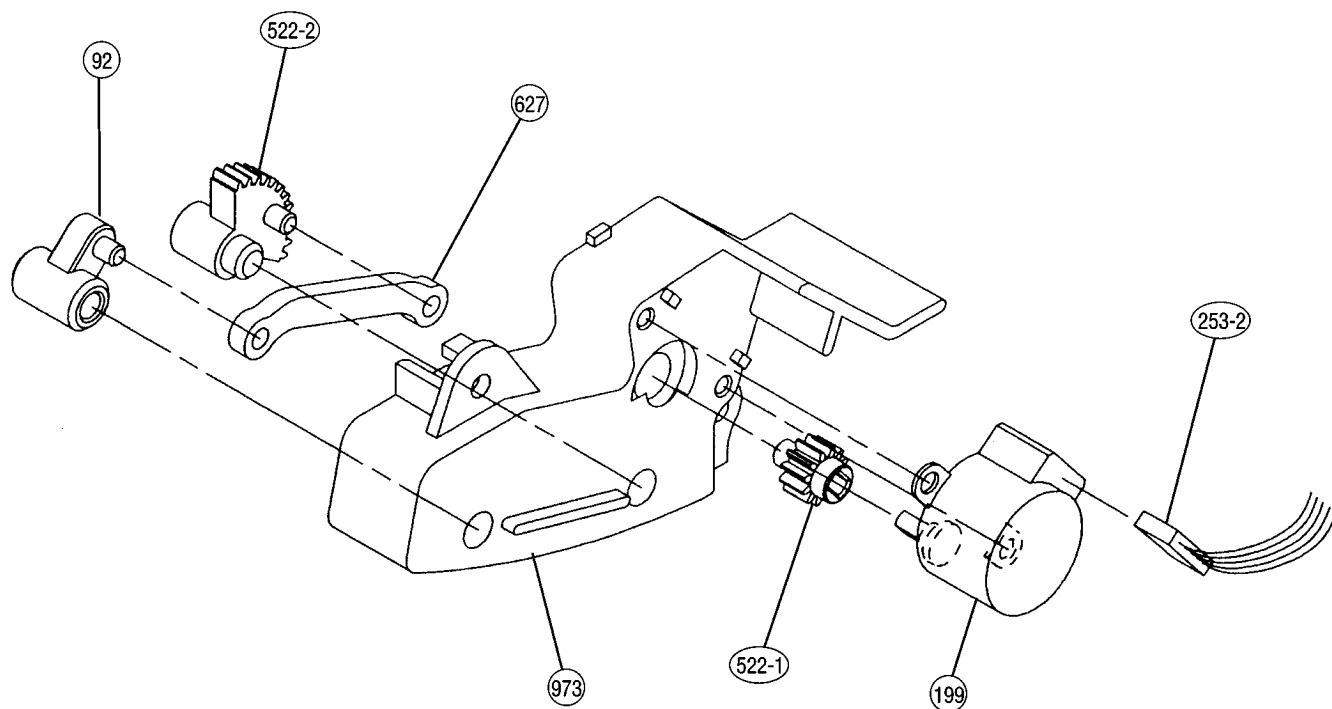

108-2

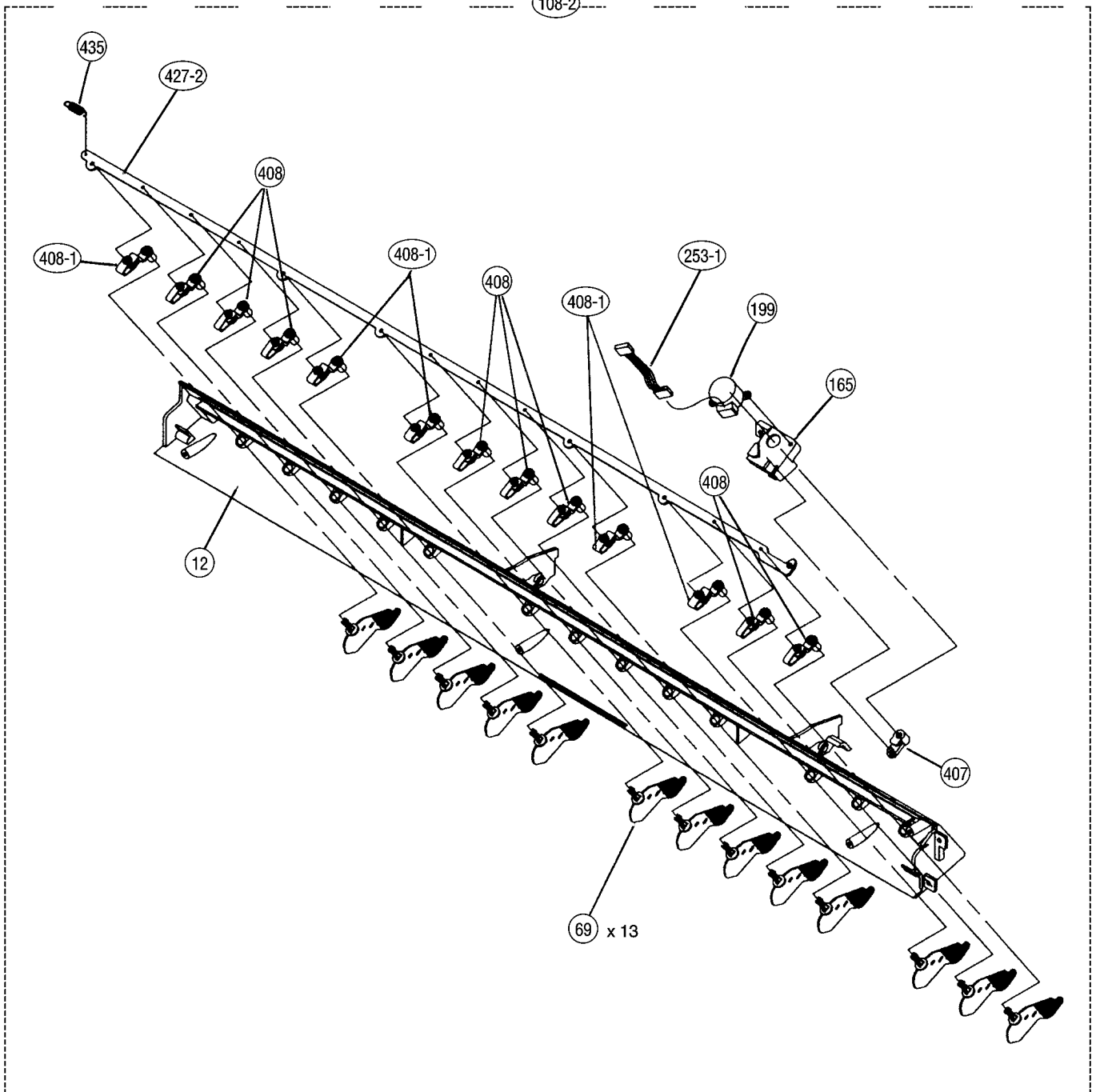

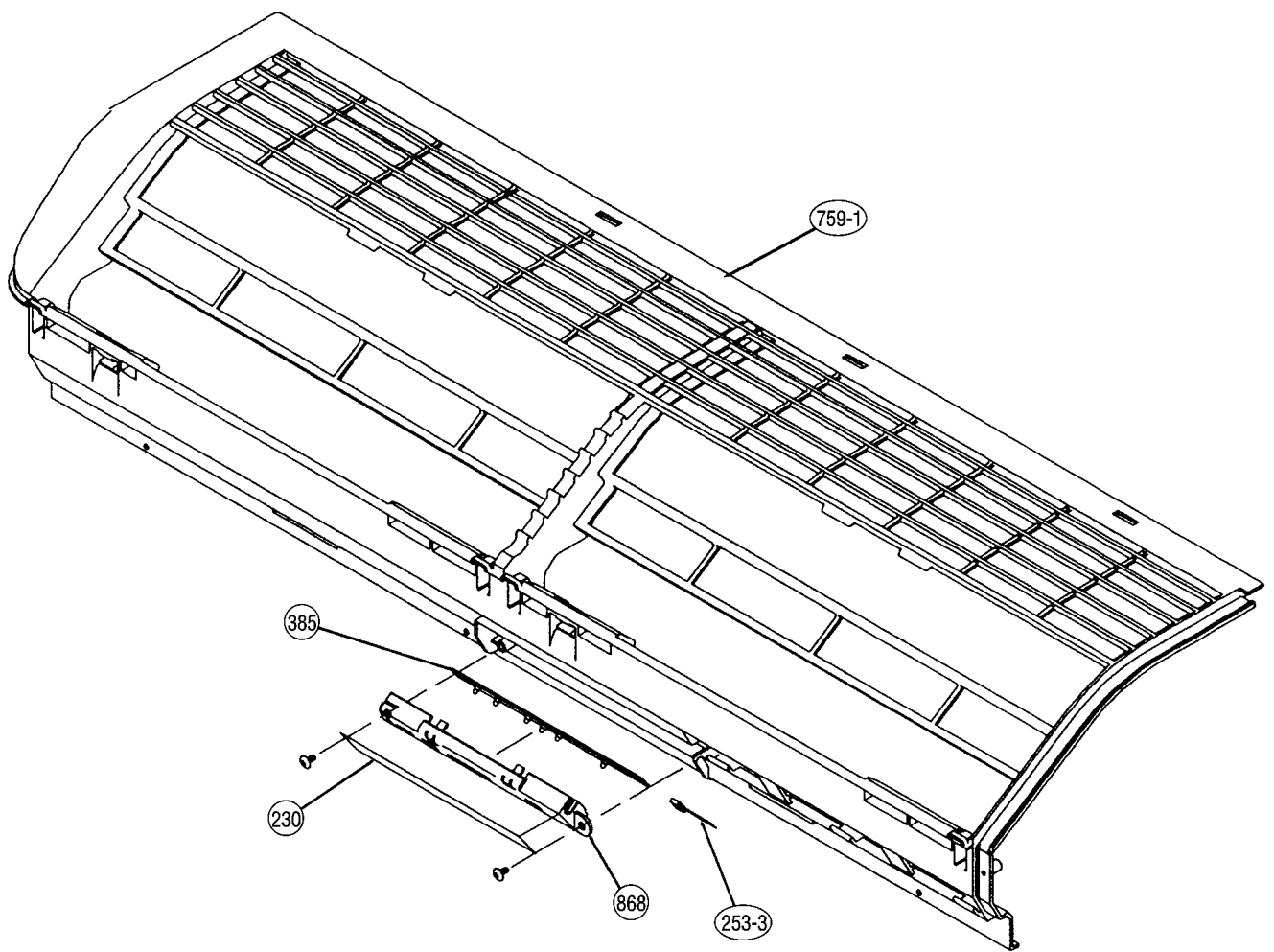

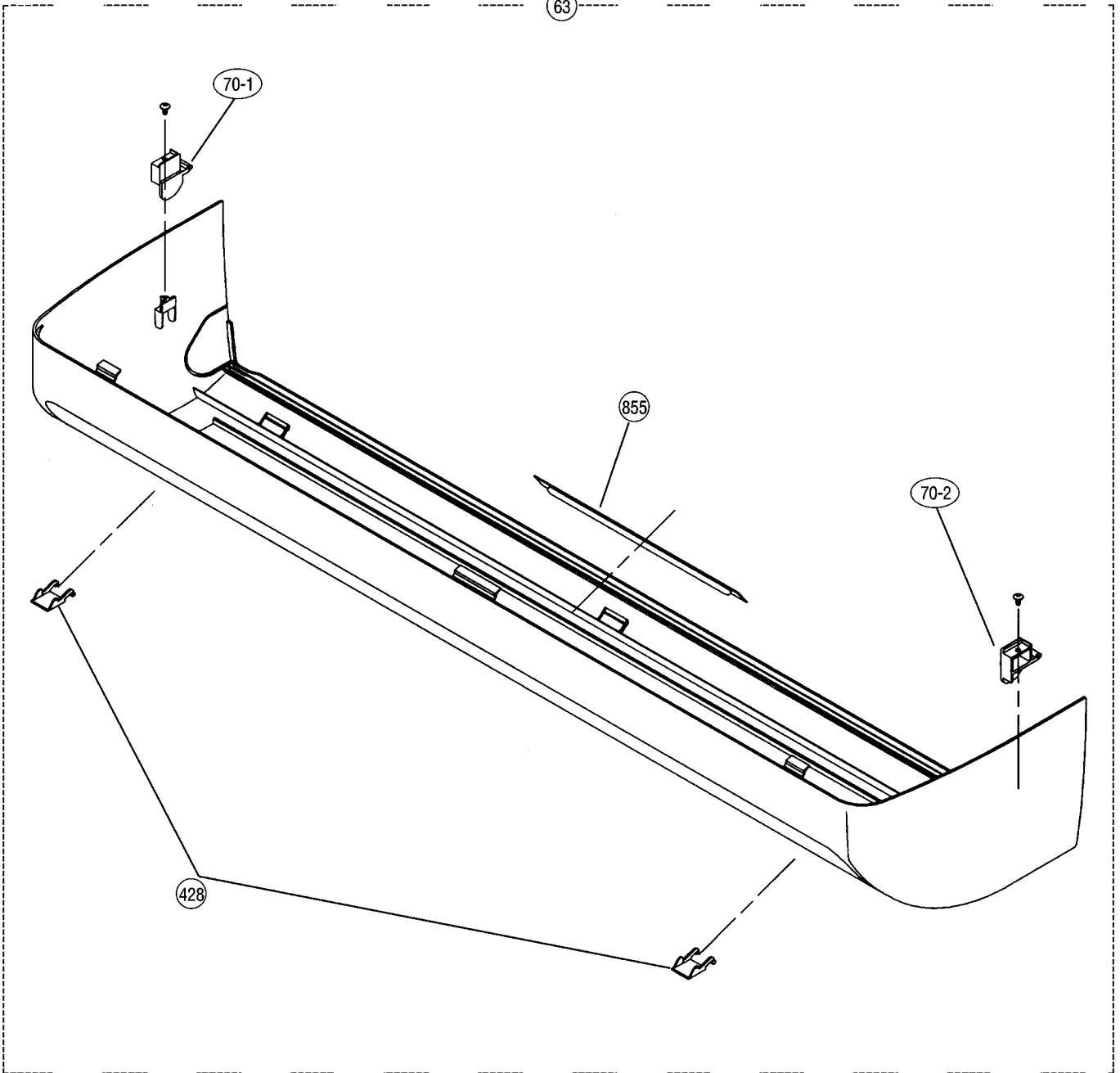

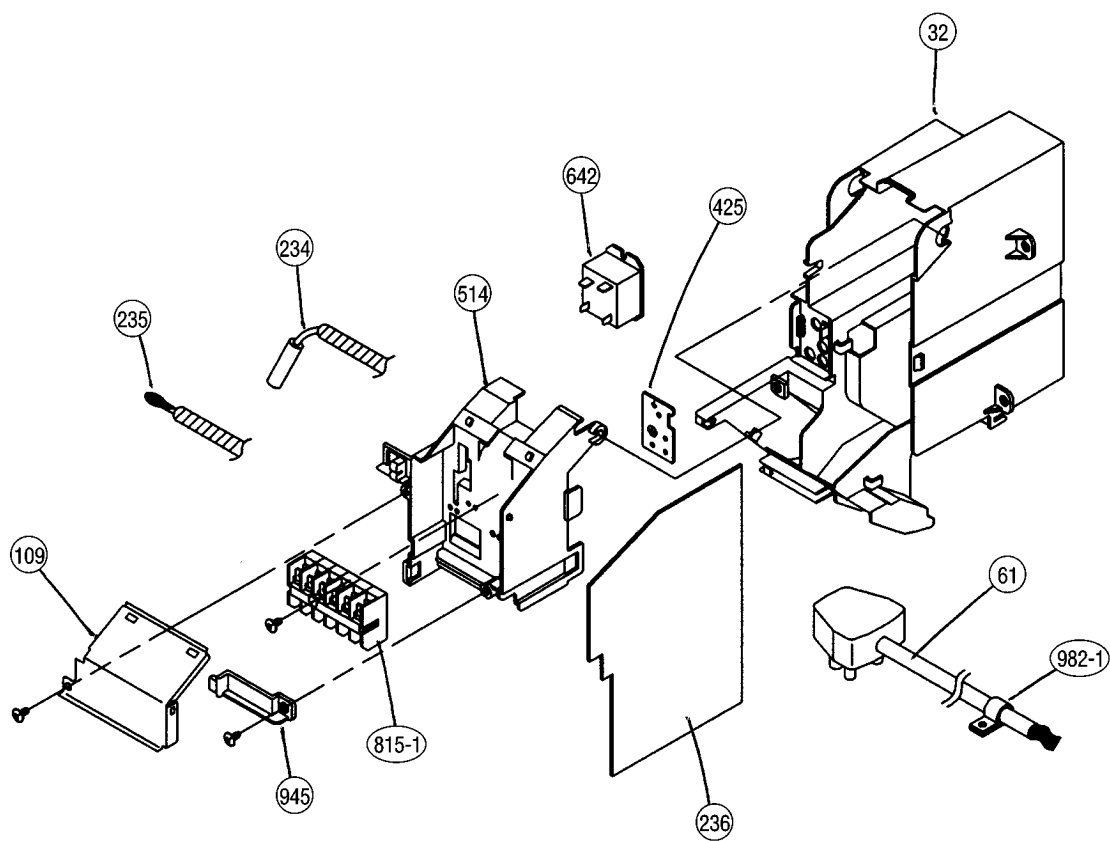

Models : ROW-18CC
ROW-24CC

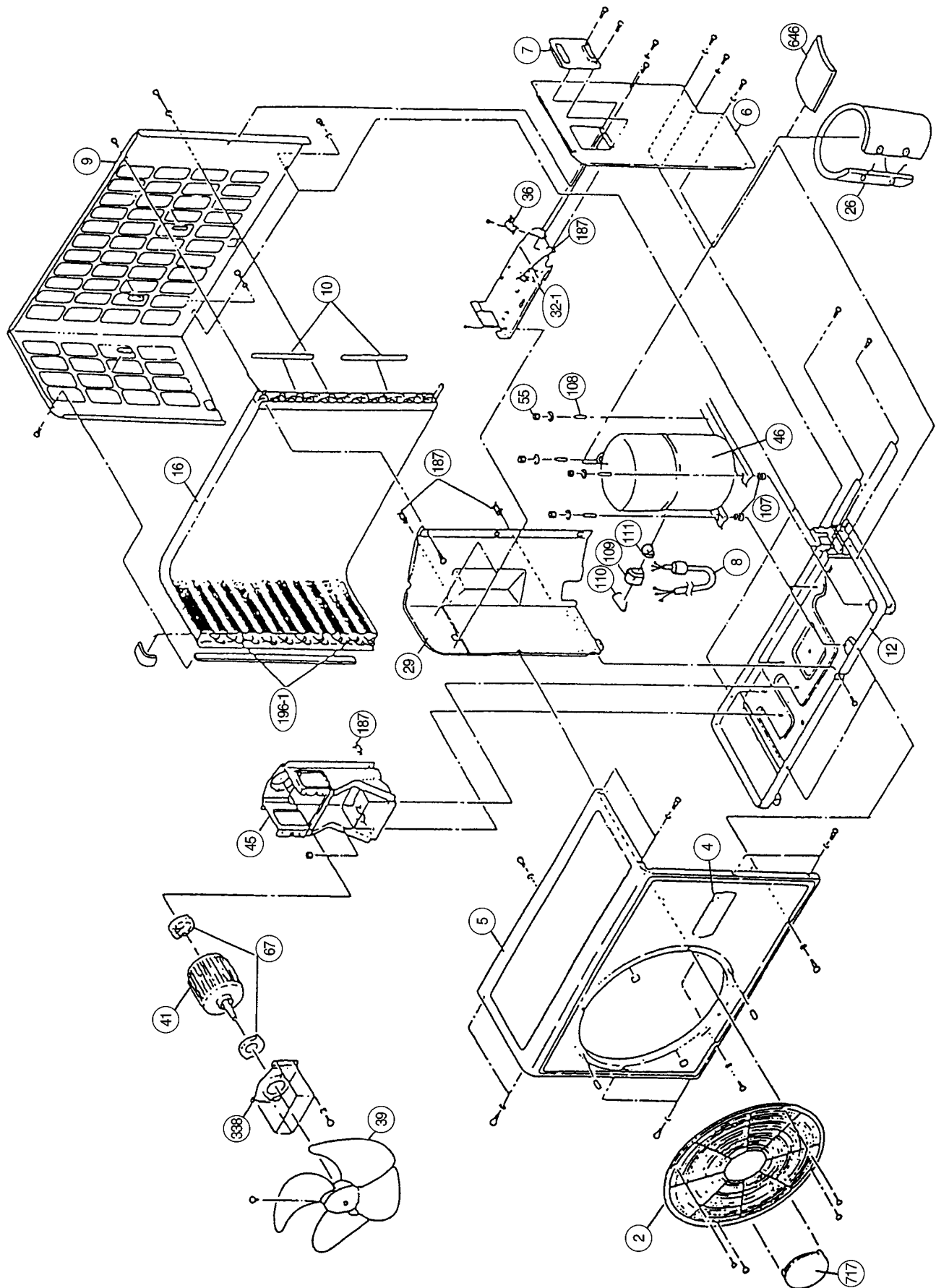

Model : ROW-18CC

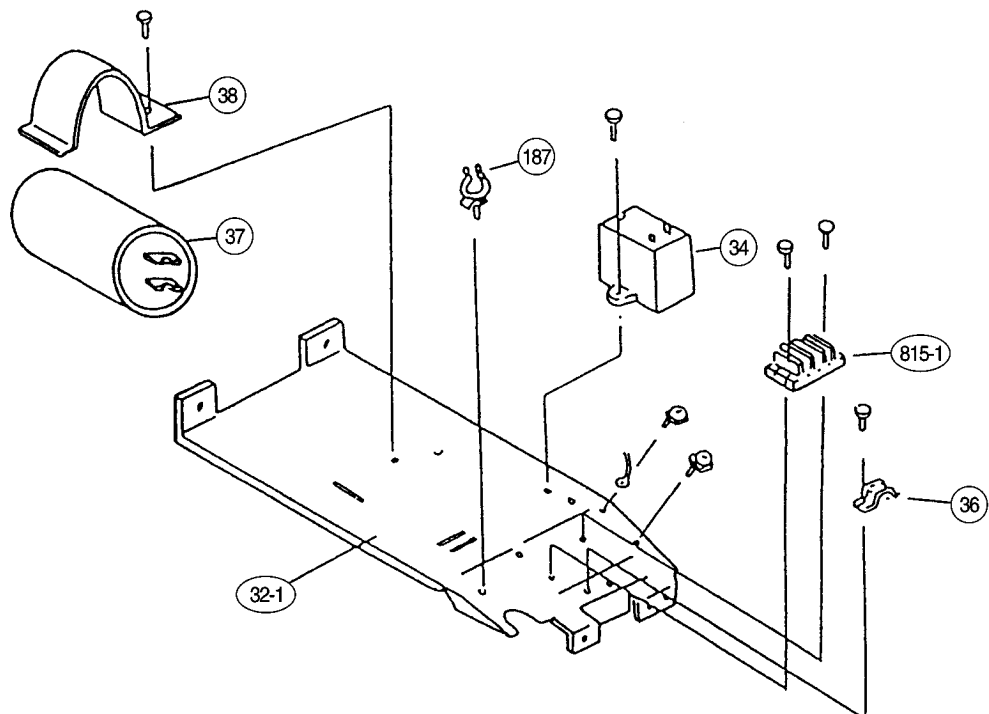
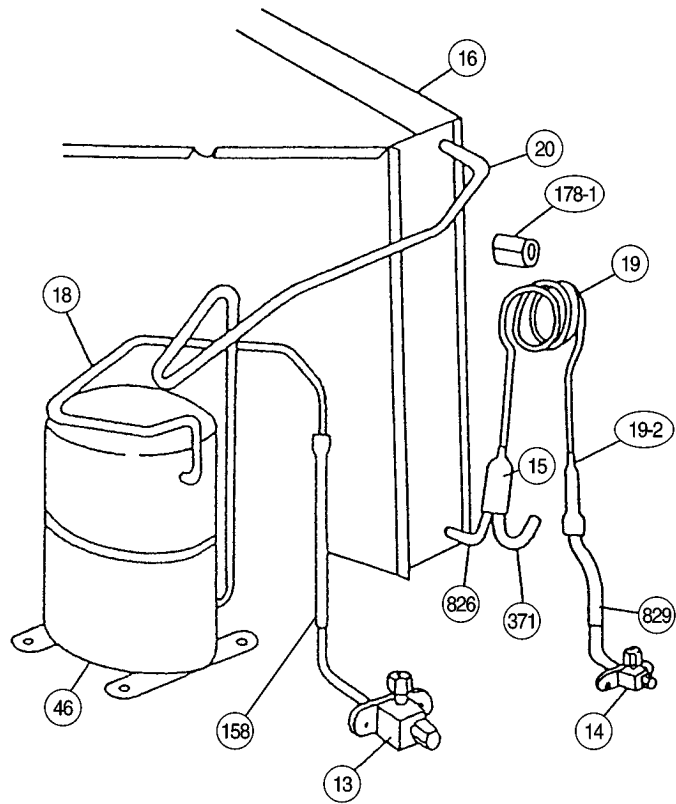

Model : ROW-24CC

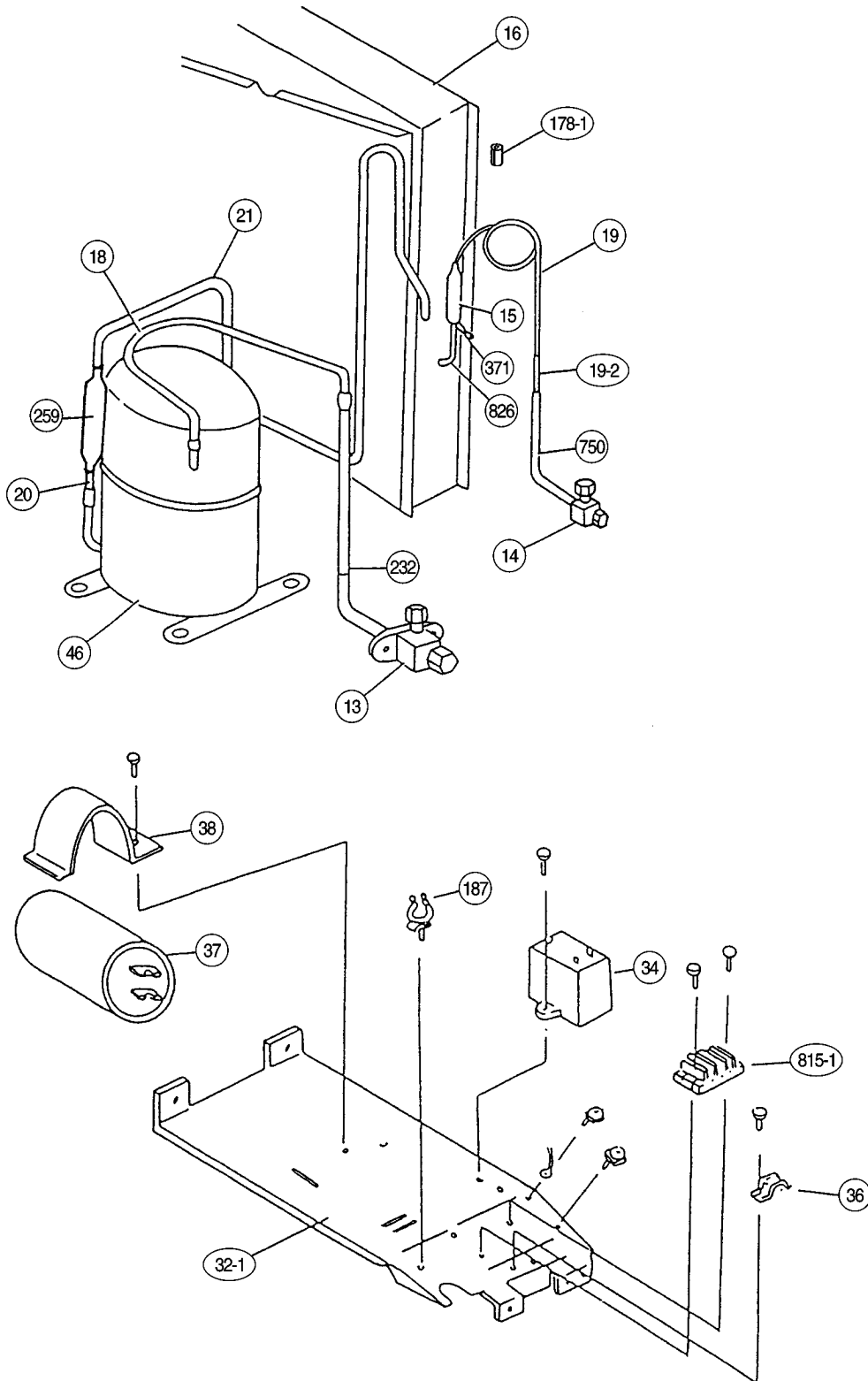

Model : ROW-30CC

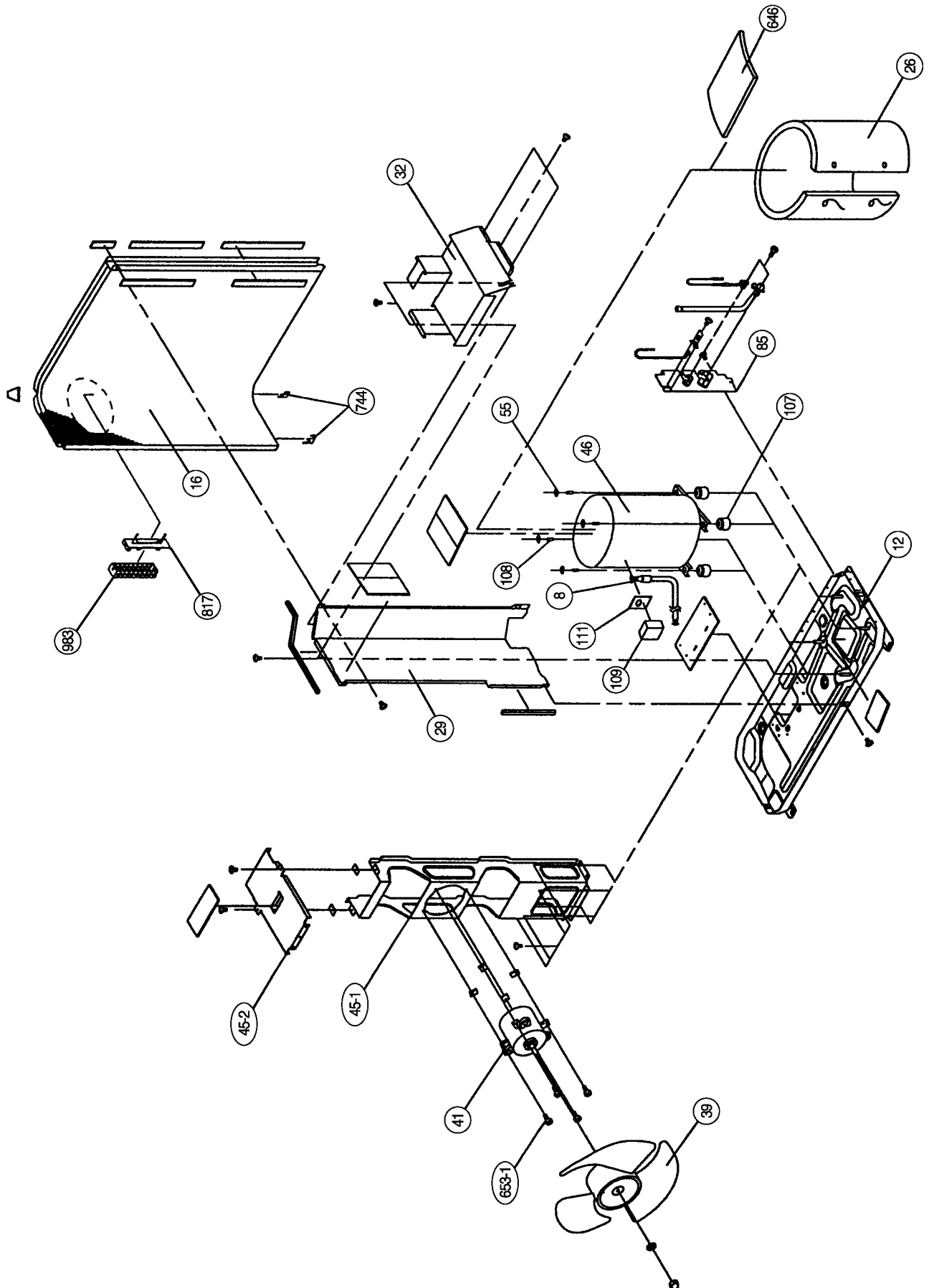

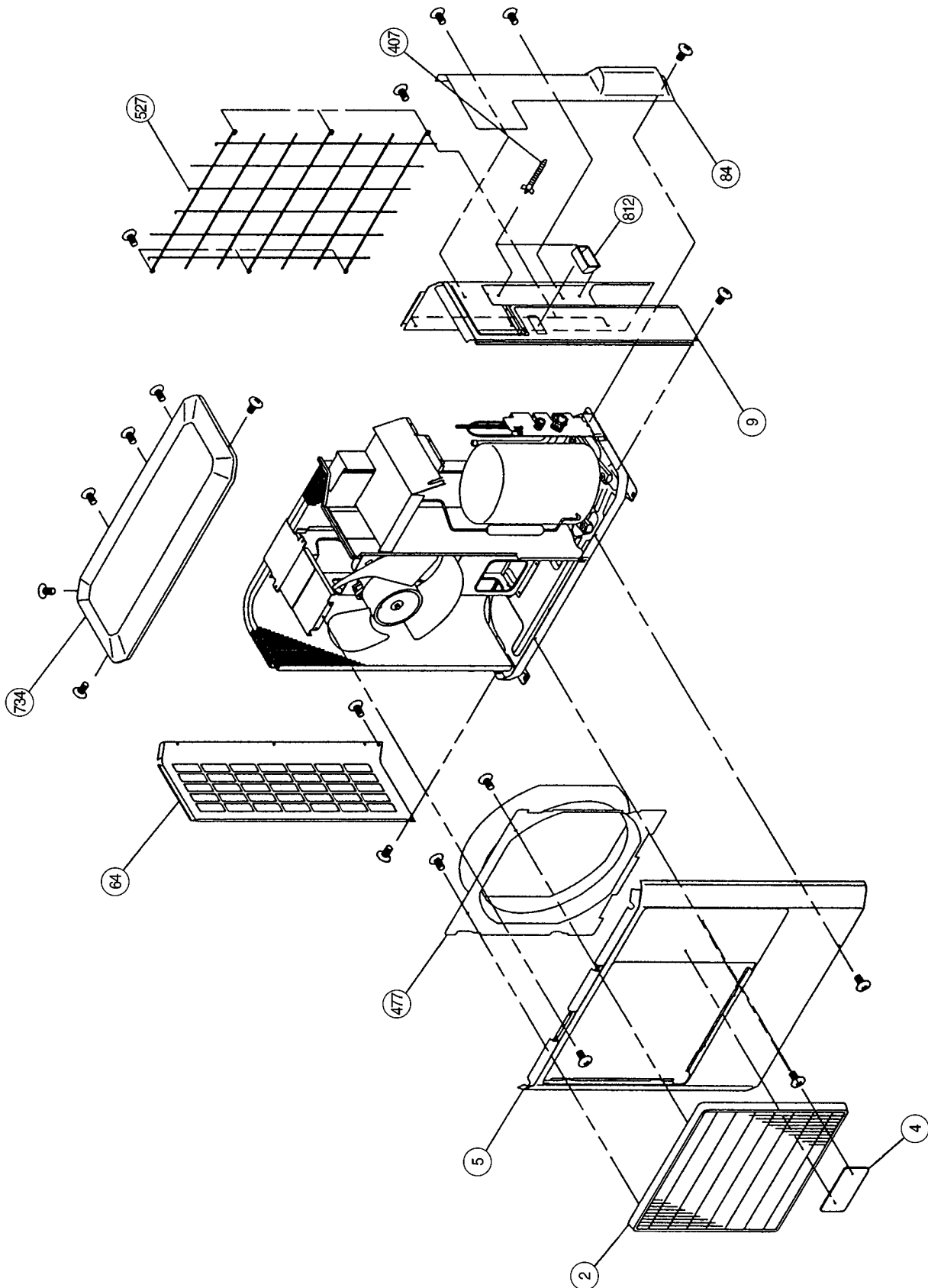

PARTS LIST

INDOOR UNIT

When you order parts, please make a photocopy of this page and fill the number of the parts in the "Order" column.

Ref. No.	Description	Part No.			Ord.
		RJW-18CC	RJW-24CC	RJW-30CC	Q'ty
8-2	Filter Frame	9367681013	9367681013	9367681013	
12	Base-B	9368216016	9368216016	9368216016	
32	Control Box	9367663002	9367663002	9367663002	
45	Bracket (Eva.) Assy	9369317019	9369317019	9369317019	
61	Power Cord Assy	9703244056	9703244056	—	
62	Fan Motor-Inner	9601385011	9601385011	9601385011	
63	Front Cover Assy	9369194030	9369194030	9369194030	
63-1	Service Cover Assy	9368837013	9368837013	9368837013	
67	Rubber (Motor)	9367676002	9367676002	9367676002	
69	Louver	9367706013	9367706013	9367706013	
70-1	Hook (Cover)-L	9367675012	9367675012	9367675012	
70-2	Hook (Cover)-R	9367674015	9367674015	9367674015	
92	Link Arm	9367694006	9367694006	9367694006	
93	Filter	9367680016	9367680016	9367680016	
108	Base	9367683017	9367683017	9367683017	
108-1	Base Assy	9368829018	9368829018	9368829018	
108-2	Base-B Assy	9368843014	9368843014	9368843014	
109	Terminal CVR	9368022006	9368022006	9368022006	
120	Eva. Sub Assy	9368832018	9368832018	9368832025	
122	Rub (Bearing) Assy	9368998004	9368998004	9368998004	
127	Drain Hose	9367695003	9367695003	9367695003	
146	Evaporator Assy	9368853006	9368853006	9369123009	
146-1	Evaporator Assy-B	—	—	9369124006	
158	Joint Pipe Assy	9368871000	9368871000	9369144004	
160	Drain Pan Assy	9368835019	9368835019	9368835019	
165	Motor Box	9367718009	9367718009	9367718009	
169	Cross Fan Assy	9367708000	9367708000	9367708000	
172	Pipe Bracket	9367844005	9367844005	9367844005	
172-3	Pipe Holder	9367687008	9367687008	9367687008	
174-1	Fixing Plate	9367987009	9367987009	9367987009	
184-1	Thermo. Spring-A	313728262708	313728262708	313728262708	
199	Stepping Motor	9900020019	9900020019	9900020019	
230	Diffusion Sheet	9368006013	9368006013	9368006013	
234	Thermistor Assy-Room	9703299148	9703299148	9703299148	
235	Thermistor Assy-Pipe	9703297038	9703297038	9703297038	
236	Controller PCB Assy	9704457042	9704457035	9704457059	
240	Remote Control Unit	9359913061	9359913061	9359913061	
253-1	Wire With Connector	9704434012	9704434012	9704434012	
253-2	Wire With Connector	9704435019	9704435019	9704435019	
253-3	Wire With Connector	9704433015	9704433015	9704433015	
320	Upper Flap	9367688012	9367688012	9367688012	
321	Lower Flap	9367689019	9367689019	9367689019	
329	Coupling Pipe Assy	9368865009	9368865009	9368865009	
338	Motor Holder	9367798001	9367798001	9367798001	
385	Indicator PCB Assy	9704368010	9704368010	9704368010	
407	Motor Link	9367696000	9367696000	9367696000	
407-2	Louver Rod	9367698004	9367698004	9367698004	
408	Louver Link	9367697007	9367697007	9367697007	
408-1	Louver Link-B	9368789008	9368789008	9368789008	
425	Earth Plate	9368017002	9368017002	9368017002	
428	Screw Cover	9367717019	9367717019	9367717019	
435	Louver Spring	9369030000	9369030000	9369030000	
514	Control Box Cover	9367664009	9367664009	9367664009	
522-1	Gear-A	9367691005	9367691005	9367691005	
522-2	Gear-B	9367692002	9367692002	9367692002	
557	Spring (Diffuser)	9368824006	9368824006	9368824006	
574-1	Eva. Support-R	9367684007	9367684007	9367684007	
574-2	Eva. Support-L	9367685004	9367685004	9367685004	
588	Eva. Holder	—	—	9367711000	
588-1	Eva. Holder-B	—	—	9368783006	

INDOOR UNIT (Continued)

When you order parts, please make a photocopy of this page and fill the number of the parts in the "Order" column.

Ref. No.	Description	Part No.			Ord.
		RJW-18CC	RJW-24CC	RJW-30CC	Q'ty
627	Link	9367693009	9367693009	9367693009	
629	EMI Filter	0400056133	0400056133	0400056133	
642	Relay (Main)	9353611017	9353611017	—	
652-1	Thermo. Holder Pipe	313806262805	313806262805	313806262805	
735	Distributor Assy	9368858001	9368858001	9369127007	
743	Remote Control Holder	9359955016	9359955016	9359955016	
759-1	Intake Cover	9367678013	9367678013	9367678013	
764	Drain Cap	9367677009	9367677009	9367677009	
815-1	Terminal-3P	9306489090	9306489090	9306489090	
855	Display-F	9367672028	9367672028	9367672028	
868	PWB Holder (Display)	9367679003	9367679003	9367679003	
875	PCB Assy-Switch	9704370013	9704370013	9704370013	
945	Wire Holder	9368016005	9368016005	9368016005	
960	Diffuser Assy	9368840013	9368840013	9368840013	
963	Fanguard	9368015008	9368015008	9368015008	
963-1	Fanguard Holder	9367707003	9367707003	9367707003	
973	Gear Box	9367690008	9367690008	9367690008	
982-1	Cord Clamp	9357886008	9357886008	—	
998	Bypass Pipe-A	9368857004	9368857004	—	
999	Bypass Pipe-B	9368917005	9368917005	—	

OUTDOOR UNIT

When you order parts, please make a photocopy of this page and fill the number of the parts in the "Order" column.

Ref. No.	Description	Part No.			Ord.
		ROW-18CC	ROW-24CC	ROW-30CC	Q'ty
2	Fan Cover	9350214020	9350214020	9359808015	
4	Emblem-Rear "FUJI ELECTRIC"	9361328006	9361328006	9361328006	
5	Cabinet-A, Painted	9303876015	9303876015	9359797029	
6	Cabinet-C, Painted	9353549013	9353549013	—	
7	Connector Cover	9358011010	9358011010	—	
8	Wire Assy (Shield)-D	9350215010	9350215041	9359904021	
9	Cabinet-B, Painted	9303874011	9303874011	9359798026	
10	Noise Insulation-E	313791106305	313790016305	—	
12	Base Assy, Painted	9353452016	9353452061	9359812029	
13	3-Way Valve	9364523002	9357963013	—	
13-1	3-Way Valve (5/8)	—	—	9360157003	
13-2	Packed Valve (3/8)	—	—	9360150004	
14	2-Way Valve Assy	9365021002	9357964010	—	
15	Dryer	313791082502	313781082502	9368111014	
16	Condenser Assy	9353455055	9356015010	9360280015	
18	Suction Pipe	9360518002	9360412003	—	
18-1	Suction Pipe-A	—	—	9360487001	
19	Capillary Tube	9359017004	9355977005	—	
19-2	Joint Pipe	9354268005	9354268005	—	
20	Discharge Pipe	9360522009	9357470009	—	
21	Discharge Pipe-B	—	9360411006	9360156006	
26	Compressor Cover-A	9354036000	9360639004	9353088000	
29	Separate Wall	313986033213	313986033213	9359804017	
32	Control Box Metal	—	—	9359839019	
32-1	Control Box Metal-A	9365672013	9365672013	—	
34	Capacitor (Fan Motor)	9357965017	9357965017	9357965024	
36	Cord Holder Metal	9356824001	9356824001	—	
37	Running Capacitor	9704436023	9704436023	9703107078	
38	Capacitor Clamp Metal	9351770013	9351770013	9360610010	
39	Propeller Fan	9300855013	9300855013	9359837015	
41	Fan Motor Assy-Out	9600738023	9600738023	9600832011	
45	Motor Fixing Table Assy	313029311100	313029311100	—	
45-1	Motor Bracket-Top	—	—	9359801016	
45-2	Motor Bracket	—	—	9359803010	
46	Compressor Assy	9360509055	9360391001	9360613011	
55	Special Nut M8	313252257701	313252257701	313252257701	
64	Cabinet Left	—	—	9359840022	
67	Rubber (Vibration Proof)	313659068604	313659068604	—	
82	Check Joint Assy	—	—	9360762009	
83	Check Joint Bracket	—	—	9359807018	
84	Valve Cover	—	—	9359817017	
85	Valve Fixing Plate	—	—	9359806011	
107	Rubber Seat-A (For Comp.)	313093081402	313102081406	313102081406	
108	Sleeve-A (For Comp.)	313093081706	313696081700	313696081700	
109	Terminal Cover (For Comp.)	313202059600	9355987004	9352456022	
110	Lock Wire (For Comp.)	313202059706	9355989008	—	
111	Terminal Packing (For Comp.)	313202059807	9355988001	9352456039	
158	Joint Pipe	9365312018	—	—	
178-1	Capillary Holder Rubber	313414274807	313414274807	—	
178-2	Capillary Holder Rubber	—	—	313394274808	
187	Clamp No. 1219	313361271706	313361271706	313361271706	
196-1	Clamp SKB-3M	—	312300787605	—	
218-3	Power Relay	—	—	9900074012	
232	Joint Pipe	—	9300990028	—	
259	Muffler	—	313948083902	313755083903	
338	Motor Fixture Metal	313029297108	313029297108	—	
348	Outlet Pipe (Cond.) Assy	—	—	9360171009	
349	Outlet Pipe-E	—	—	9360174000	
371	Process Pipe-B	313142082352	313142082352	—	
407	Clamp (Cable) No. 1259	—	—	313739340109	





OUTDOOR UNIT (Continued)

When you order parts, please make a photocopy of this page and fill the number of the parts in the "Order" column.



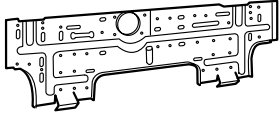
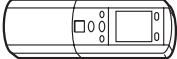

Ref. No.	Description	Part No.			Ord. Q'ty
		ROW-18CC	ROW-24CC	ROW-30CC	
450	Discharge Pipe-A	—	—	9360166005	
477	Bell-Mouth	—	—	9359809012	
527	Protection Net	—	—	9359844013	
549	Thermostat-Outdoor	—	—	9352553004	
620	Inlet Pipe (Cond.) Assy	—	—	9360167002	
646	Compressor Cover-B	313986355101	313986355101	9353368003	
653-1	Bolt (Fan Motor Fixing)	—	—	0700156014	
717	Center Plate	9351253011	9351253011	—	
734	Cabinet Top Plate, Panel	—	—	9359799023	
744	Clamp (Condenser)	—	—	313166374106	
750	Joint Pipe-A	—	9301003017	—	
812	Grip	—	—	9352157004	
815-1	Terminal-3P	9356488005	9356488005	—	
815-3	Terminal-8P	—	—	9358660119	
817	Thermostat Fixture	—	—	9352164019	
823-2	Fuse Holder	—	—	0500063024	
824-4	Fuse	—	—	0600222529	
826	Condensing Pipe-B	9353601001	9353601001	—	
829	Joint Pipe-A	9365314012	—	—	
909	Strainer-A	—	9365112014	—	
983	Thermostat Cover	—	—	9358274002	
989-1	Cord Clamp-A	—	—	9359822011	
989-2	Cord Clamp-B	—	—	9359823018	

STANDARD ACCESSORIES





INDOOR UNIT ACCESSORIES

Name and Shape	Part No.
Wall hook bracket 	9367987009
Remote control unit 	9359913061 (AR-DL6)
Battery (penlight) 	0600185534
Remote control unit holder 	9359955016
Tapping screw (big) ($\varnothing 4 \times 20$) 	301141164200
Tapping screw (small) ($\varnothing 3 \times 12$) 	301141533125

OUTDOOR UNIT ACCESSORIES (18,000 • 24,000BTU model)

Name and Shape	Part No.
Hexagon wrench 	9351228019
Drain pipe 	313728031005
Flexible tube 	313013042915
Drain cap 	313166024302

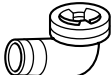
OUTDOOR UNIT ACCESSORIES (30,000 BTU model)

Name and Shape	Part No.
Hexagon wrench 	9351228019
Cable clip 	313739340109
Tapping screw 	301463040100
Drain pipe 	9303029015
Drain cap 	313166024302



MANUFACTURER :

Fuji Denki Sosetsu Co., Ltd.

Tokyo, Japan

0206J2058



Большая библиотека технической документации

<https://splitsystema48.ru/instrukcii-po-ekspluatacii-kondicionerov.html>

каталоги, инструкции, сервисные мануалы, схемы.